

Pivot arms for drop-down doors

1 PIVOT ARM WITH ADJUSTABLE BRAKE AND AUTOMATIC CLOSING		<i>pp.</i> 150
--	---	-------------------------

2 PIVOT ARM WITH AUTOMATIC BRAKE	 151
---	---	-----------

3 "2-HAND" PIVOT ARM	 152
-----------------------------------	---	-----------

4 4 PIVOT ARM WITH TWIN-ADJUSTMENT BRAKE	 153
---	---	-----------

1 PIVOT ARM WITH ADJUSTABLE BRAKE AND AUTOMATIC CLOSING

PIVOT ARM THAT CAN BE USED WITH BOTH HANDS. IT HAS AN ELEGANT DESIGN, SCREW-ON ASSEMBLY, SELF-CLOSING SYSTEM AND MANUAL OPENING SPEED ADJUSTMENT.

ALUMINIUM CARCASS

SILVER ANODIZED	813.035.510	100
-----------------	-------------	-----

CARCASS IN ALUMINIUM, BODY AND BRACKETS IN STEEL.

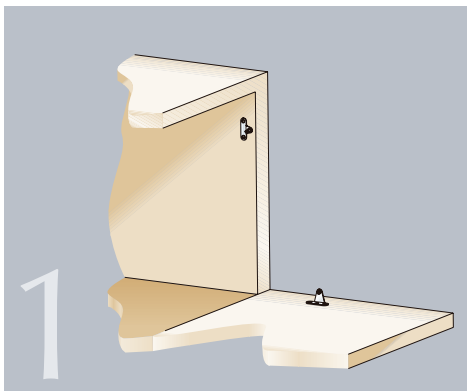
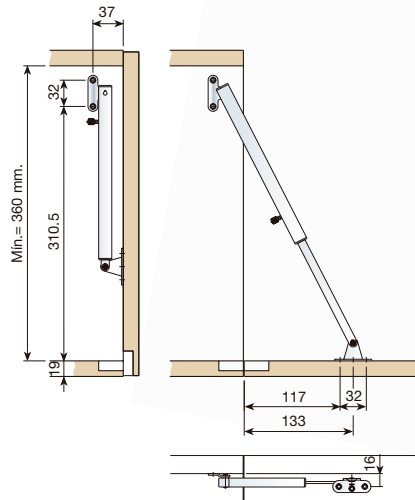

1 SCREW BRACKETS TO THE CABINET SIDE
BRACKETS CAN BE USED FOR THE RIGHT OR THE LEFT.

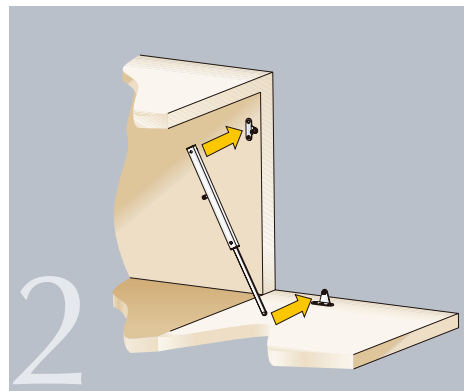

2 CLIP ON THE PIVOT ARM TO THE BRACKETS.

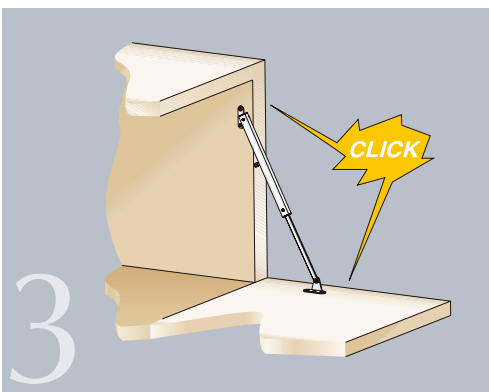

3 IT CAN BE MANUALLY ADJUSTED JUST BY TURNING THE SCREW.

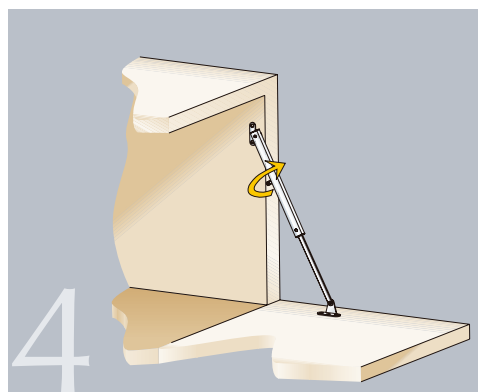

2 PIVOT ARM WITH AUTOMATIC BRAKE

PIVOT ARM WITH METAL STRUCTURE.

			LEFT	RIGHT	
NICKEL-PLATED	300		823.530.061	823.130.066	100
NICKEL-PLATED	370		823.537.061	823.137.066	

THE CLAMPING SUPPORTS AND THE BRAKE ADJUSTERS ARE MADE OF BLACK NYLON.



PIVOT ARM WITH NYLON STRUCTURE.

			LEFT	RIGHT	
BROWN	RAL 8016	300	813.530.012	813.130.010	100
BROWN	RAL 8016	370	813.537.012	813.137.010	
BLACK	RAL 9005	300	813.530.023	813.130.021	
BLACK	RAL 9005	370	813.537.023	813.137.021	

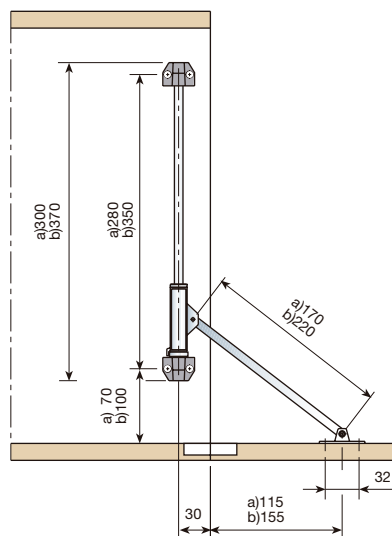
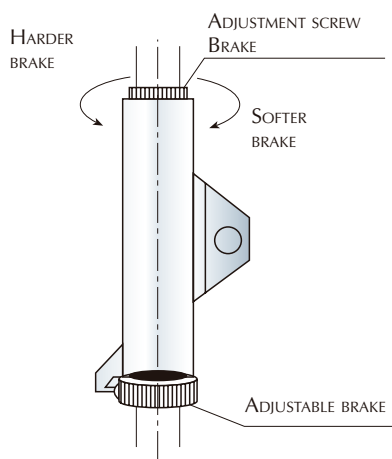

3 "2-HAND" PIVOT ARM

"2-HAND" PIVOT ARM THAT CAN BE USED BOTH FOR THE RIGHT AND LEFT SIDES.

PIVOT ARM.

				D	
WHITE	RAL 9003	256	813.925.000		
WHITE	RAL 9003	288	813.928.006		
WHITE	RAL 9003	320	813.932.000		
BROWN	RAL 8016	256	813.925.011		
BROWN	RAL 8016	288	813.928.010	100	
BROWN	RAL 8016	320	813.932.011		
BLACK	RAL 9005	256	813.925.022		
BLACK	RAL 9005	288	813.928.021		
BLACK	RAL 9005	320	813.932.022		

THE CLAMPING SUPPORTS AND THE BRAKE ADJUSTERS ARE MADE OF BLACK NYLON.

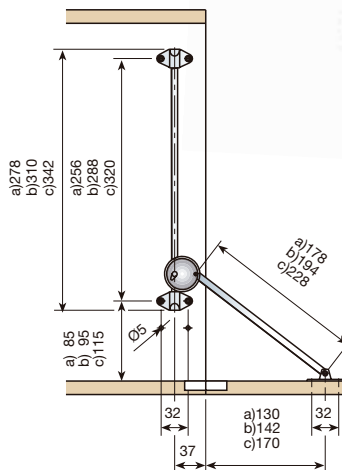
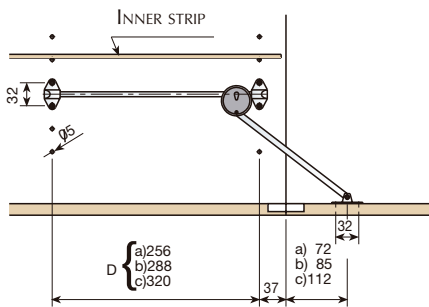

NYLON HEADLESS NUT.

				
NATURAL		949.500.101	200	

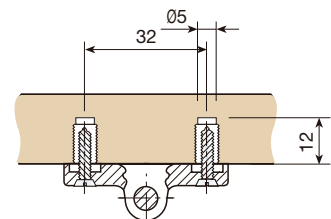

4 PIVOT ARM WITH TWIN-ADJUSTMENT BRAKE

PIVOT ARM WITH AUTOMATIC BRAKE. QUICK ADJUSTMENT USING THE LATERAL SCREW. TIGHTEN THAT SCREW TO ACHIEVE MAXIMUM BRAKING.

PIVOT ARM WITH TWIN-ADJUSTMENT BRAKE.

			
WHITE	RAL 9003	819.900.001	
BROWN	RAL 8016	819.900.012	100
BLACK	RAL 9005	819.900.023	



A BRAKE ADJUSTMENT SCREW

