







Fittings for lift-up doors

| | | |
|--|---|-------------------------|
| 3 PIVOT ARMS FOR LIFT-UP DOORS |  | <i>pp.</i> 174 |
| 4 PIVOT ARM FOR LIFT-UP LIDS |  | ... 175 |
| 5 HINGE FOR LIFT-UP DOORS |  | 175 |
| 6 LIFTING DEVICE WITH SPRING |  | 176 |
| 7 HYDRAULIC LIFTING DEVICE..... |  | 177 |
| 8 FITTING FOR LIFT-UP DOORS (MICROWAVE) |  | 178 |
| 9 2-DOOR LIFTING DEVICE |  | 179 |

3 PIVOT ARMS FOR UP-AND-OVER DOORS

THE BODY AND ARM MAY BE ASSEMBLED SEPARATELY, AS THE ENSEMBLE MAY BE DISMANTLED.

THIS PIVOT ARM COMES IN NICKEL-PLATED ZAMAK OR IN PLASTIC, AND CAN BE USED FOR RIGHT OR LEFT-HAND DOORS.

250 MM PIVOT ARM, WITH DETACHABLE ARM.

| | | | |
|---------------|--|-------------|---|
| | | |  |
| NICKEL-PLATED | | 826.900.060 | 100 |

SCREWS SUPPLIED WITH THE ITEM.

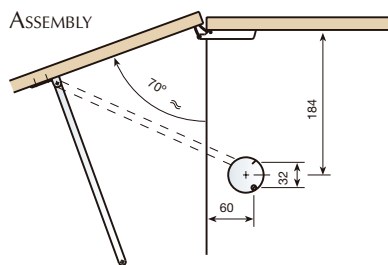

PIVOT ARM FOR LIFT-UP DOORS, PARTICULARLY FOR KITCHEN CUPBOARDS. IT CAN BE USED FOR RIGHT OR LEFT-HAND DOORS.

250 MM PIVOT ARM.

| | | | |
|--------|----------|-------------|---|
| | | |  |
| WHITE | RAL 9003 | 816.900.000 | 100 |
| BROWIN | RAL 8016 | 816.900.011 | |

SCREWS SUPPLIED WITH THE ITEM.

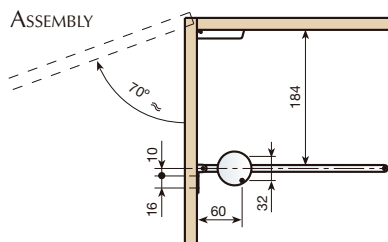

How to use

TO OPEN, LIFT THE DOOR TO THE TOP; LET IT FALL AND IT WILL REMAIN IN A FULLY-FITTED OPEN POSITION, WITH MAXIMUM SAFETY.

TO CLOSE, SLIGHTLY LIFT THE DOOR AND IT WILL AUTOMATICALLY BE RELEASED FROM ITS FIXTURE, AND CONTINUE ITS COURSE A FEW CENTIMETRES BEFORE CLOSING. IT HAS A BRAKE SYSTEM TO PREVENT KNOCKS AND THUS ENSURE THE DOOR REMAINS FULLY CLOSED.

4 PIVOT ARM FOR LIFT-UP LIDS

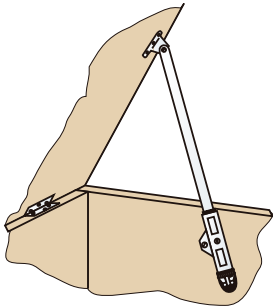

PIVOT ARM FOR LIFT-UP LIDS. LENGTH 250MM.

| WHITE | RAL 9003 | 814.900.004 | | |
|-------|----------|-------------|-----|--|
| BROWN | RAL 8016 | 814.900.015 | 100 | |
| BLACK | RAL 9005 | 814.900.026 | | |

5 HINGES FOR UP-AND-OVER DOORS

A hinge with endless advantages:

- THE DOOR OPENS UPWARDS AND LEAVES ACCESS FREE. THE INSIDE IS CLEARLY VISIBLE AND THE DOOR SYSTEM WORKS SMOOTHLY.
- THE DOOR LIFTS UP AUTOMATICALLY AND IS RETAINED IN THE UTMOST SAFETY. OPENING ANGLE: 76°.
- EASY ASSEMBLY BOTH ON THE DOOR AND THE CABINET SIDE. GREATER COMFORT WHILE WORKING.
- THE STEEL SPRINGS ARE TOP QUALITY AND ENSURE A HIGH LEVEL OF STABILTY AND PERFECT CLOSING.
- ANTI-CORROSION PROTECTION.
- APPROVED BY THE INDEPENDENT FURNITURE CONTROL INSTITUTE.

HINGE FOR LIFT-UP DOORS DE 180 N.

| | LEFT | RIGHT | |
|---------------|-------------|-------------|----|
| WHITE | 800.101.805 | 800.102.800 | 20 |
| NICKEL-PLATED | 800.101.061 | 800.102.063 | |

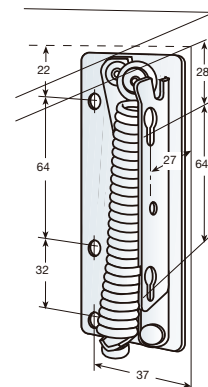

HINGE FOR LIFT-UP DOORS UP TO 220 N WITH ADJUSTMENT.

| | LEFT | RIGHT | |
|-------|-------------|-------------|----|
| WHITE | 800.201.802 | 800.202.804 | 20 |

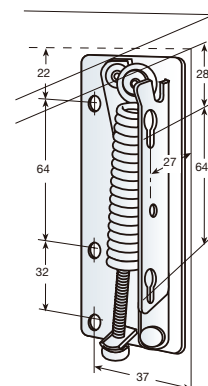

6 LIFTING DEVICE WITH SPRING



LIFTING DEVICE WITH SPRING.

| | | |
|-------|-------------|---|
| | | |
| WHITE | 806.400.000 | 1 |

EVERY REFERENCE CONTAINS 1 RIGHT-HAND LIFTING DEVICE, 1 LEFT-HAND LIFTING DEVICE, 1 SPRING FOR 5 KG DOORS (PRE-MOUNTED), 1 SPRING FOR 7 KG DOORS (SPARE), 1 SET OF WHITE PLASTIC COVERS.

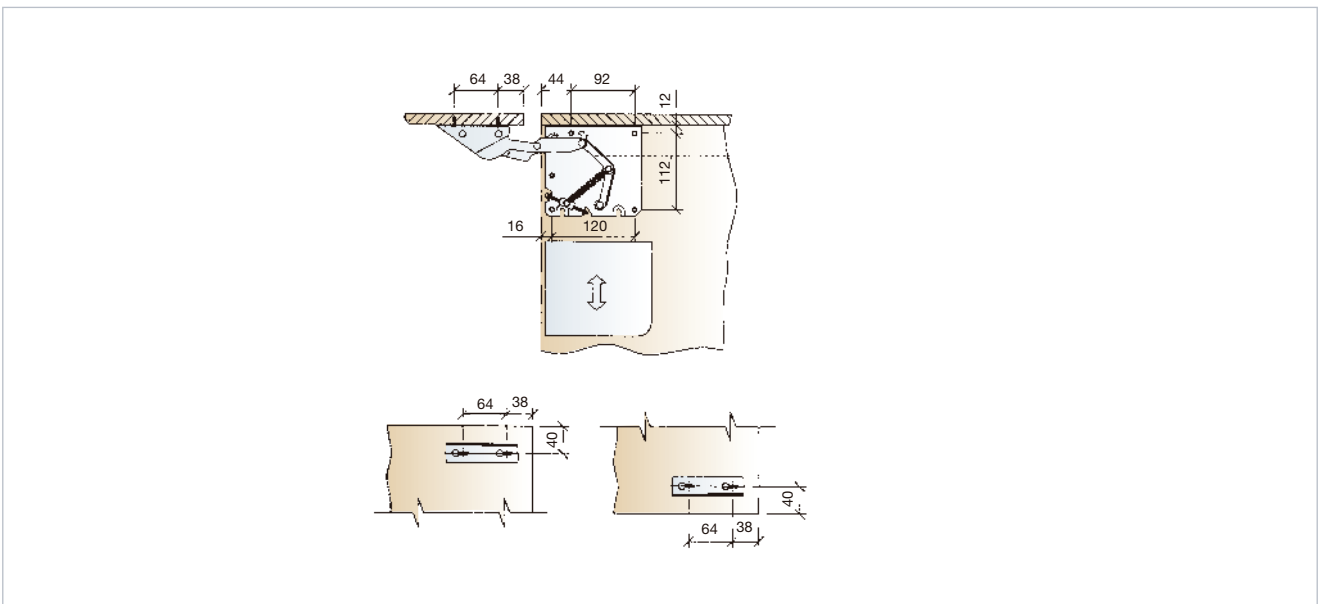

7 HYDRAULIC LIFTING DEVICE



HYDRAULIC LIFTING DEVICE.

| | | |  |
|-------------|-------------|--|---|
| LIFTING SET | 806.101.310 | | 10 |

EVERY REFERENCE CONTAINS 1 RIGHT-HAND LIFTING DEVICE, 1 LEFT-HAND LIFTING DEVICE, 12 SCREWS TO ASSEMBLE THE LIFTING DEVICE.

STABILISER BAR.

| | | |  |
|-------|-------------|--|---|
| MODEL | | | |
| 300 | 807.130.310 | | |
| 350 | 807.135.313 | | |
| 400 | 807.140.316 | | |
| 450 | 807.145.312 | | |
| 500 | 807.150.315 | | 10 |
| 600 | 807.160.314 | | |
| 800 | 807.180.312 | | |
| 900 | 807.190.311 | | |
| 1200 | 807.199.315 | | |

CALCULATED FOR 16 MM SIDE.

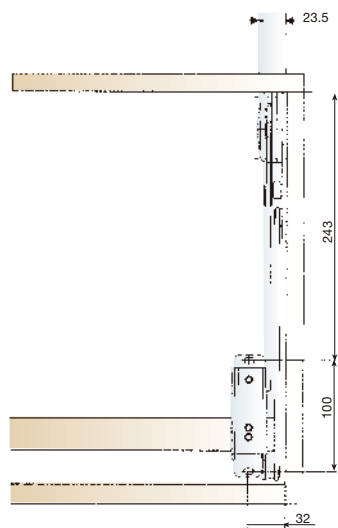
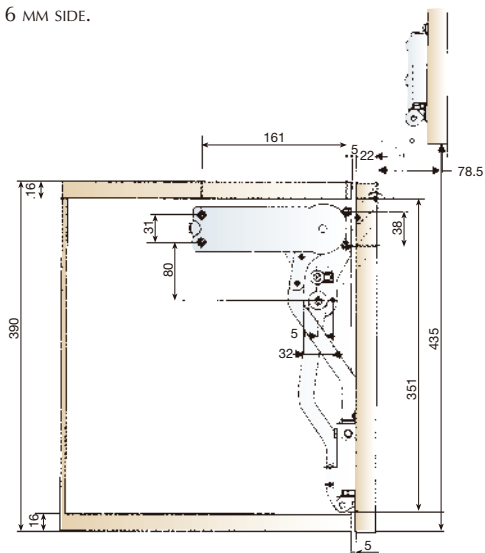

8 FITTING FOR LIFT-UP DOORS (MICROWAVE)

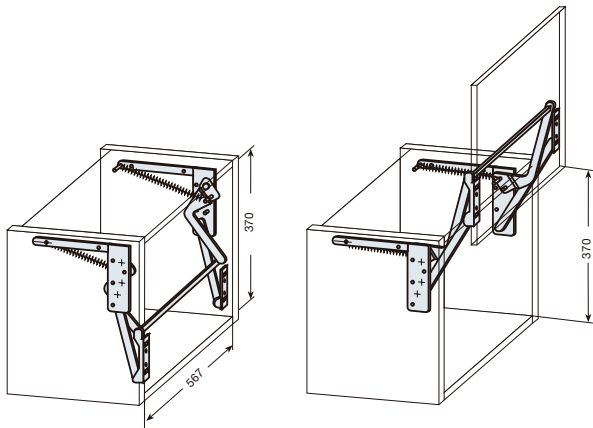

FITTING FOR LIFT-UP DOORS (MICROWAVE).

| | | |
|-------|-------------|---|
| | |  |
| WHITE | 803.060.005 | 4 |

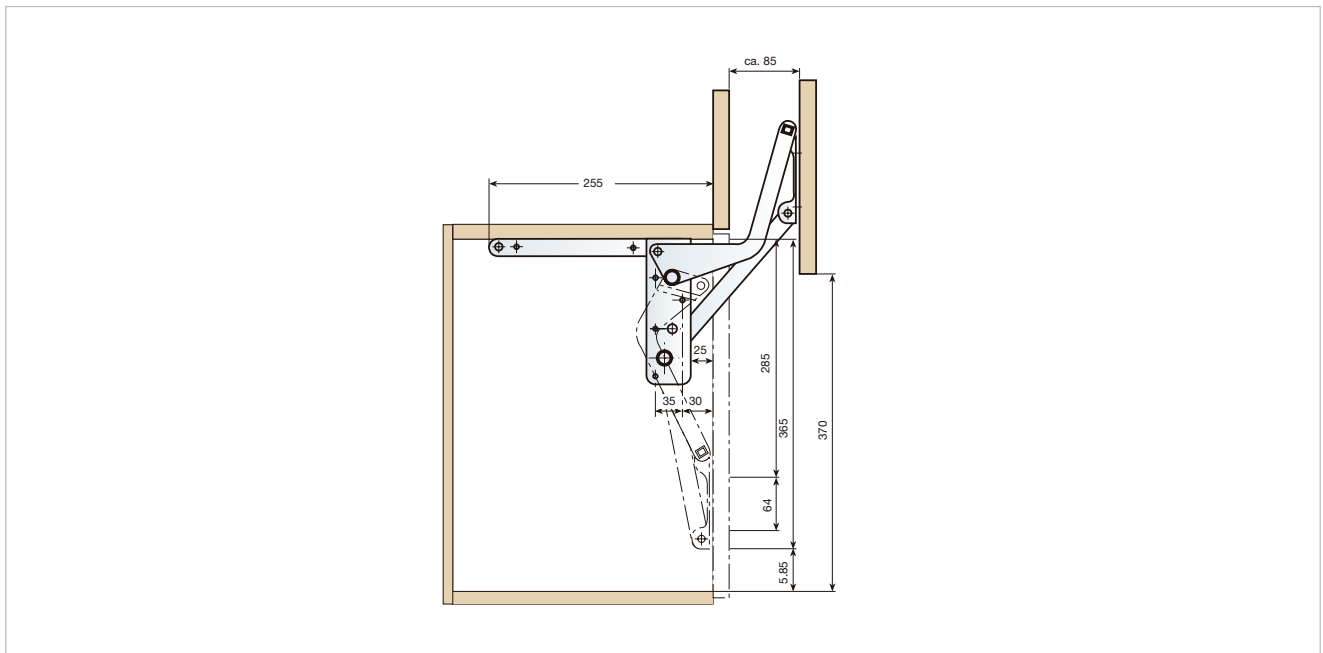

9 2-DOOR LIFTING DEVICE



2-DOOR LIFTING DEVICE

| | | |
|------|-------------|----|
| GREY | 806.200.312 | 10 |
|------|-------------|----|

EVERY REFERENCE HAS 1 RIGHT-HAND LIFTING DEVICE, 1 LEFT-HAND LIFTING DEVICE, 18 ASSEMBLY SCREWS, 2 RUBBER STOPS, 1 ALLEN KEY.

ASSEMBLY TABLE

| DOOR HEIGHT | A | B | C | D |
|-------------|-----|-------|-----|----|
| 340 | 116 | 232-S | 225 | 50 |
| 350 | 104 | 242-S | 230 | 45 |
| 360 | 91 | 253-S | 235 | 35 |

FOR DOORS UP TO 900 MM WIDE. THE TOTAL WEIGHT OF THE TWO DOORS MUST NOT EXCEED 7 KGS.

