

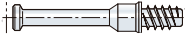
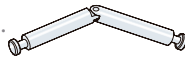
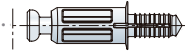

UNIVERSAL Ø15 MM CAM ASSEMBLY FOR ALL OUR  
BOLT MODELS, INCLUDING HIGH TOLERANCE SELF-  
EXPANDING MODELS.

# Universal assembly Ø15 cam

# Ø15 Cam

CAM

<b>1</b>	<b>CAMS AND COVERS</b> .....		<i>pp.</i> ..... 245
<b>2</b>	<b>BOLTS</b> .....		246
■	SINGLE BOLTS .....		246
■	ARTICULATED AND TWIN BOLTS .....		247
■	EXPANDING BOLTS .....		248
<b>3</b>	<b>NUTS</b> .....		..... 250

# 1 CAMS AND COVERS

## Ø4 MM. COVER CAP.

			
WHITE	RAL 9003	531.217.002	
BROWN	RAL 8016	531.217.013	2.000 OR 10.000
BLACK	RAL 9005	531.217.024	
NICKEL-PLATED		531.217.061	

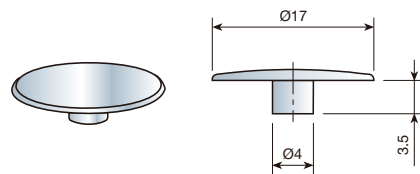





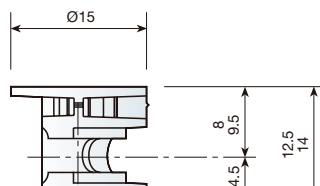
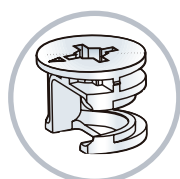
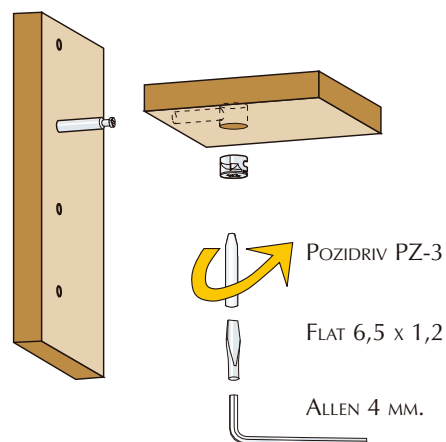

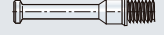

## Ø15 MM. CAM.

PANEL THICKNESS	16 MM.	19 MM.	
C	8 MM.	9,5 MM.	
NATURAL	511.108.102	511.195.101	
BLACK ZINC-PLATED	511.108.043	511.195.042	2.000
BICHROMATED	511.108.054	511.195.053	
NICKEL-PLATED	511.108.065	511.195.064	

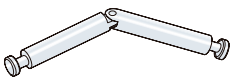

THE Ø15 MM. CAM CAN BE USED WITH ANY OF OUR CONNECTING BOLTS.

	WOOD THREADED STEEL-CONNECTING BOLT
	WOOD THREADED ZAMAK-CONNECTING BOLT
	M6 STEEL CONNECTING BOLT
	M6 ZAMAK CONNECTING BOLT
	HIGH TOLERANCE SELF-EXPANDING BOLT
	CONNECTING BOLT WITH SAFETY WASHER
	CONNECTING BOLT
	ARTICULATED CONNECTING BOLT
	90° ANGLE CONNECTING BOLT

## 2 BOLTS

### SINGLE BOLTS

#### WOOD THREADED CONNECTING BOLT.

	D= 34 MM.	
ZINC-PLATED STEEL	523.834.032	2.500
NATURAL ZAMAK	524.334.101	2.000

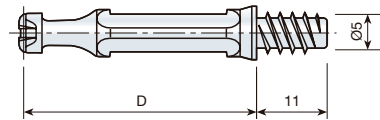
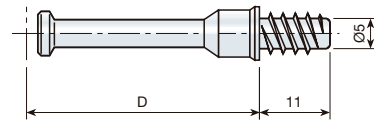
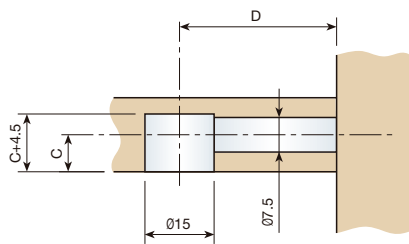

#### M6 CONNECTING BOLT.

	D= 34 MM.	
ZINC-PLATED STEEL	523.934.036	2.500
NATURAL ZAMAK	524.434.105	2.000

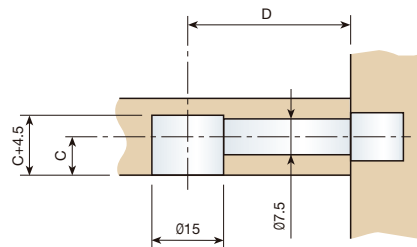
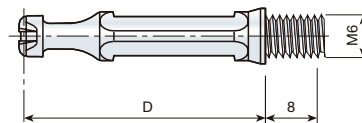
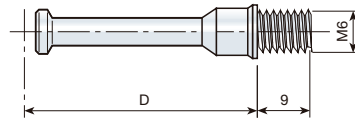
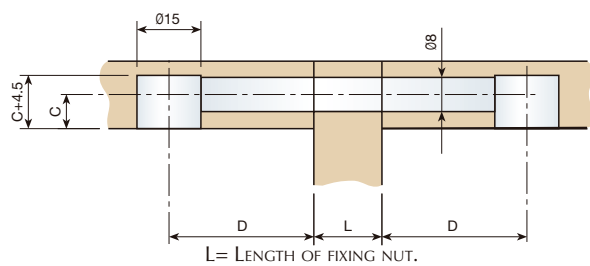

■ ARTICULATED AND TWIN BOLTS

ARTICULATED BOLT.

ZINC-PLATED	524.144.036	1.000
-------------	-------------	-------

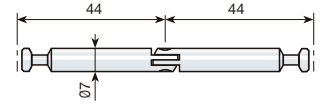
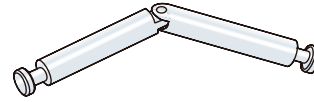
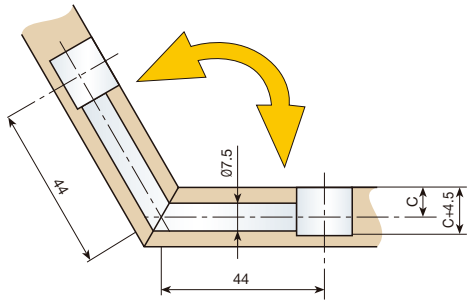

ANGLE CONNECTING-BOLT.

ZINC-PLATED	D= 34 MM. 524.634.036	1.000
-------------	--------------------------	-------

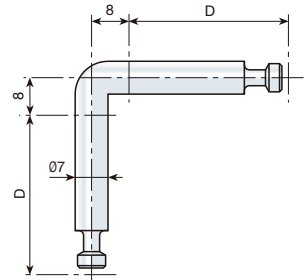
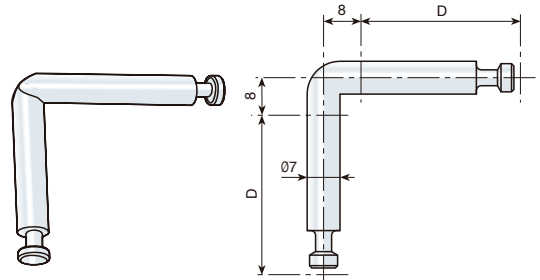
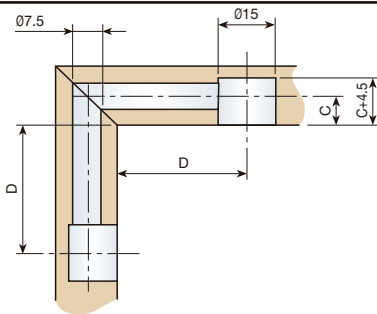

DOUBLE-ENDED CONNECTING BOLT.

ZINC-PLATED	D= 34 MM. 524.834.030	1.000
-------------	--------------------------	-------

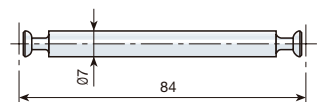
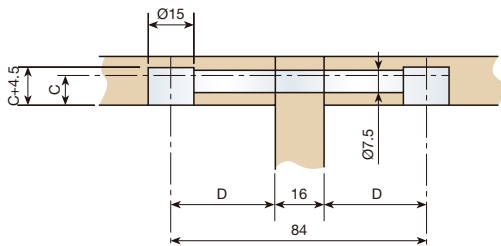

DOUBLE-ENDED CONNECTING BOLT WITH WASHER.

ZINC-PLATED		1.000
D= 24 MM	524.724.034	
D= 34 MM	524.734.033	

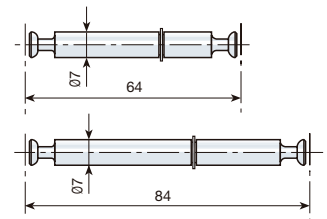
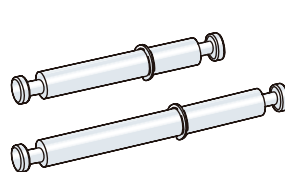
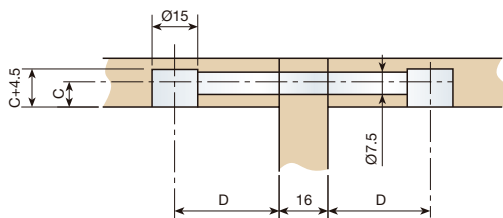

**SELF-EXPANDING BOLTS**

THIS BOLT GIVES SAVES SUBSTANTIAL ASSEMBLY TIME, FOR EITHER PRODUCTION ASSEMBLY, OR FOR KD FURNITURE. AVAILABLE FOR 24 AND 34 DRILLING CENTRES. FOR 5.8 OR 10 MM DRILLING ON THE GABLE END.

SELF-EXPANDING BOLT.

NATURAL	Ø5 MM.	Ø8 MM.	Ø10 MM.	
D= 24 MM.	525.224.103	525.324.100	525.424.104	2.000
D= 34 MM.	525.234.102	525.334.106	525.434.103	

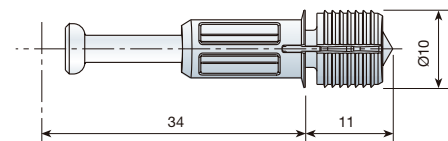
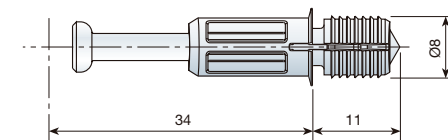
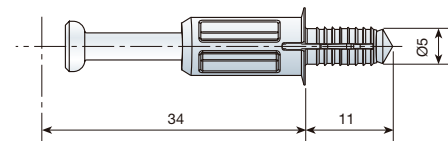
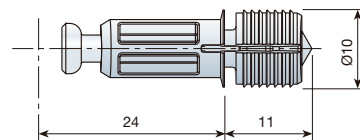
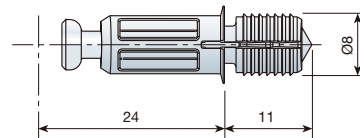
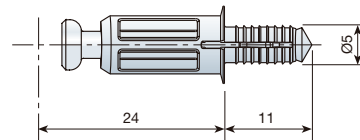

IT CAN BE FITTED OR REMOVED FROM ITS HOUSING BY HAND, TOOL-FREE.

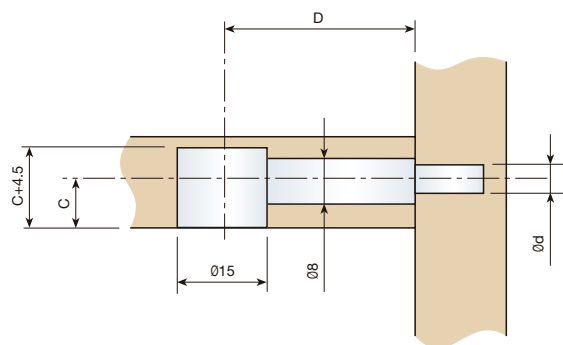

### Assembly

WHEN TURNING THE CAM THE ROD IS MOVED AND THE PORTION HOUSED IN THE GABLE END IS SIMULTANEOUSLY EXPANDED, SO STRONG AND EFFICIENT INTERLOCKING IS ACHIEVED.

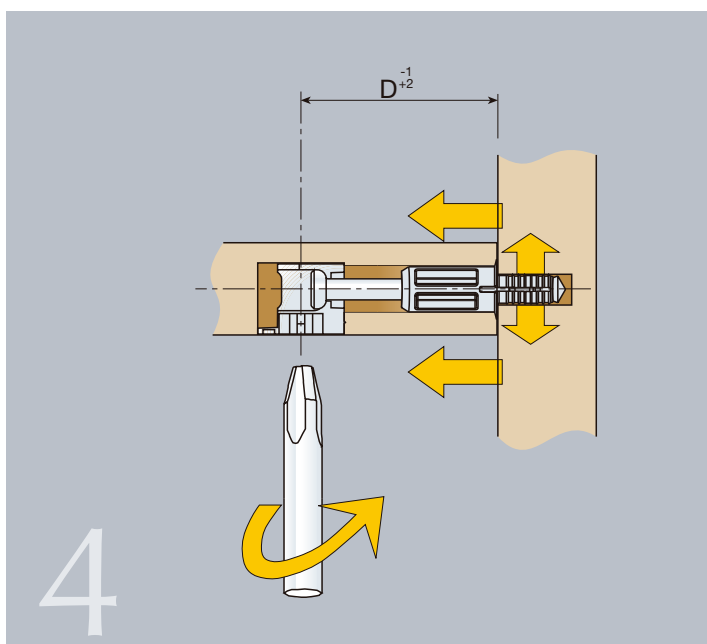
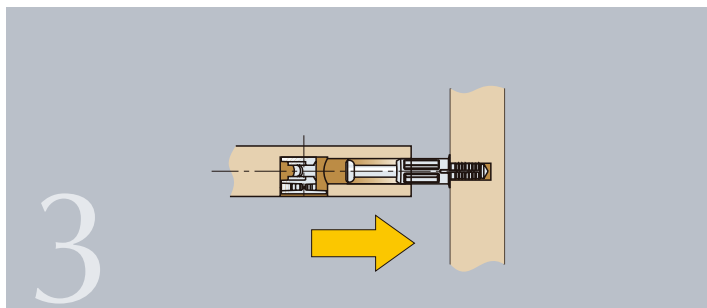
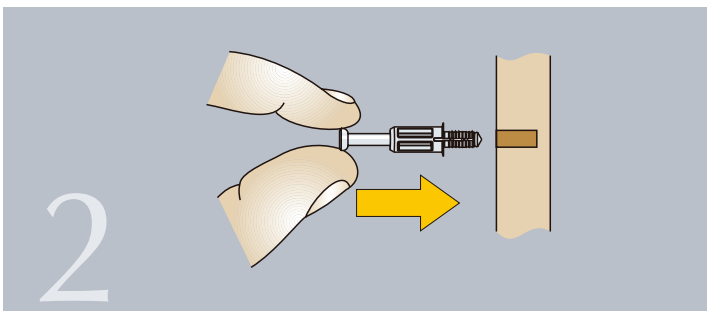
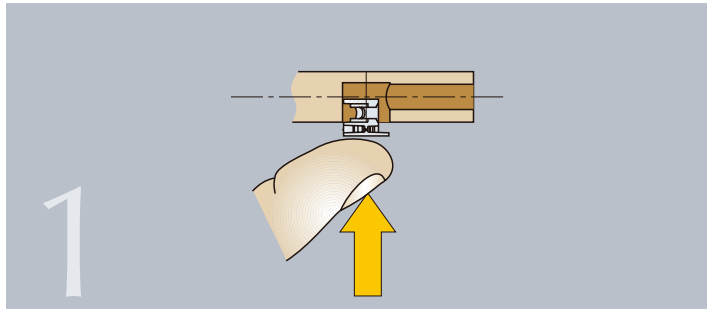

## 5 NUTS

### STEEL WOOD-THREADED NUT WITHOUT HEAD.

BICHROMATED					
L (MM.)	Ød(MM.)	ØD (MM.)	1/4"	M6	
10	8	10	947.510.056	947.810.054	2.500
12	8	10	947.512.053	947.812.051	2.000
14	8	10	947.514.050	947.814.055	2.000
18	8	10	947.518.051	947.818.056	2.000
22	8	10	947.522.052	947.822.050	2.000
10	9	12	947.610.053	947.910.051	2.000
12	9	12	947.612.050	947.912.055	2.000
14	9	12	947.614.054	947.914.052	2.000
16	9	12	947.616.051	947.616.051	2.000
18	9	12	947.618.055	947.918.053	2.000

  

L (MM.)	Ød(MM.)	ØD (MM.)	M8	
22	11	14	948.222.052	1.500

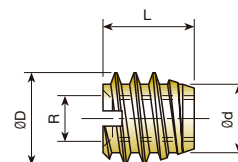

### EXPANDING BRASS NUT.

M4				
			944.805.105	2.000 OR 10.000

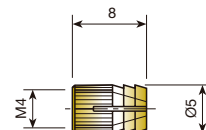

### M6 SELF-EXPANDING.

M6				
Ø8 x 12 MM.			944.112.105	5.000

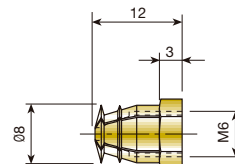

### WING NUT.

		1/4"	M6	
BICHROMATED			948.913.055	2.000
ZINC-PLATED		948.813.036		

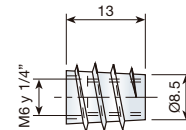

### WING NUT WITH HEAD.

		1/4"	M6	M8	
BICHROMATED			948.713.054	2.000	
ZINC-PLATED		948.613.035	948.515.035		

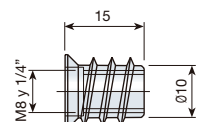
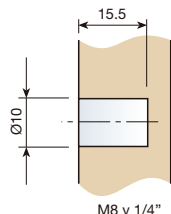
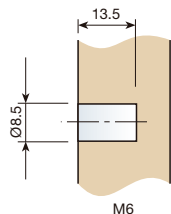
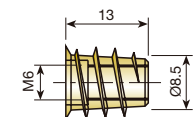



M4 NYLON KNOCK-IN NUT FOR Ø8.

			
NATURAL		937.004.106	2.000 OR 10.000
BROWN	RAL 8016	937.004.014	

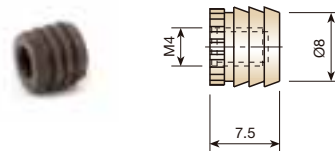

NYLON KNOCK-IN NUT FOR Ø10.

R	M6	1/4"	
NATURAL	937.006.103	937.014.105	
BROWN	RAL 8016 937.006.011	937.014.013	2.000 OR 10.000
BLACK	RAL 9005 937.006.022	937.014.024	

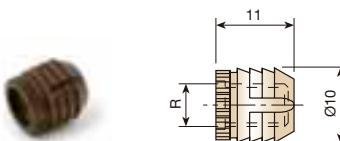

NYLON KNOCK-IN NUT FOR Ø11.

R	M6	1/4"	
NATURAL	937.106.100	937.114.102	2.000 OR 10.000
BROWN	RAL 8016 937.106.015	937.114.010	

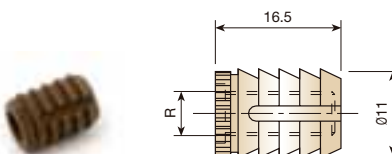

M6 NYLON KNOCK-IN NUT FOR Ø10, IN STRIPS.

			
NATURAL		937.406.105	
BROWN	RAL 8016	937.406.013	4.800
BLACK	RAL 9005	937.014.024	

EVERY BOX CONTAINS 200 STRIPS.  
THE STRIPS COME WITH 24 UNITS, AND THEY MAY BE PLACED MANUALLY OR BY MEANS OF A PNEUMATIC GUN WITH A CHARGER.

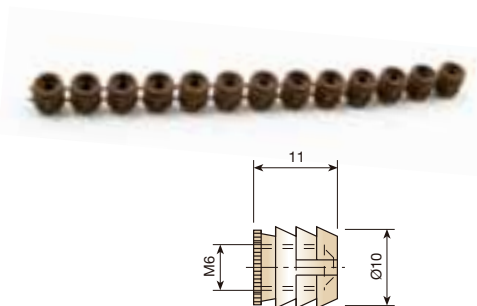

M6 STEEL RIBBED NUT.

L	16 MM.	18 MM.	
ZINC-PLATED	938.716.100	938.718.104	1.000 OR 5.000

