

Joining assemblies

JOINING ASSEMBLIES

	<i>pp.</i>
1 ASSEMBLY SCREWS	280
■ COVERS	280
■ SCREWS	280
<hr/>	
2 JOINING ASSEMBLIES	281
<hr/>	
3 KNOCK-IN BODIES	282
<hr/>	
4 SCREWS	283
<hr/>	
5 NUTS	284

1 ASSEMBLY SCREWS

COVERS

SHORT COVER Ø35 MM.

			
NICKEL-PLATED		530.500.062	
WHITE	RAL 9003	530.500.003	1.000
BROWN	RAL 8016	530.500.014	
BLACK	RAL 9005	530.500.025	

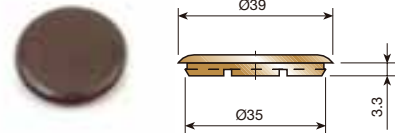

COVER WITH COUPLING PINS Ø35 MM.

			
WHITE	RAL 9003	530.700.004	
BROWN	RAL 8016	530.700.015	1.000
BLACK	RAL 9005	530.700.026	

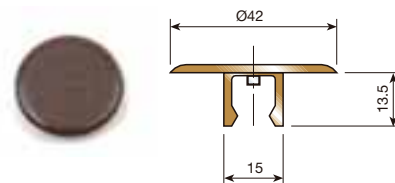

SCREWS

ASSEMBLY SCREW WITH CRENELLATED HEAD 1/4".

			
ZINC-COATED		581.532.033	1.000

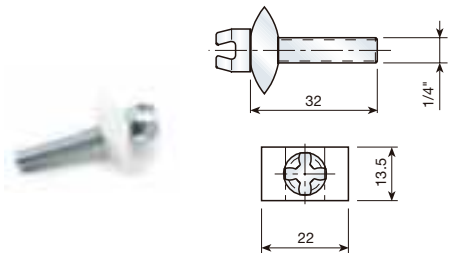

WOOD-THREADED NUT WITHOUT HEAD 1/4".

			
BICHROMATED		947.614.054	2.000

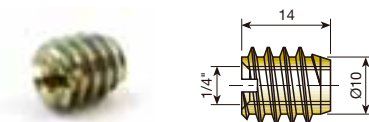

ASSEMBLY SCREW WITH CRENELLATED HEAD.

			
LENGTH		1/4"	
32		581.432.106	2.000



SPECIAL WING WASHER.

			
NATURAL		570.000.104	2.000



DIRECTLY TIGHTENED
WITH SCREWDRIVER

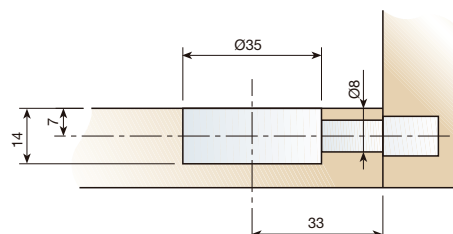
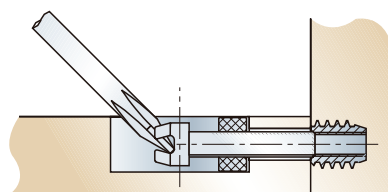

2 JOINING ASSEMBLY

ASSEMBLY COVER.

			
WHITE	RAL 9003	530.300.002	
BROWN	RAL 8016	530.300.013	1.000
BLACK	RAL 9005	530.300.024	

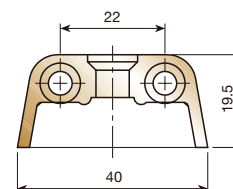

FIXING SCREW 3/16".

			
ZINC-COATED		952.518.033	500 OR 2.000

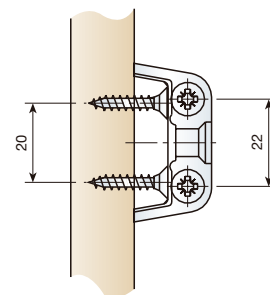

SINGLE THREAD ASSEMBLY BODY.

			
NATURAL		550.100.106	1.000

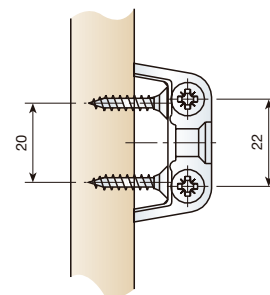

METAL-THREADED FIXING SCREW Ø5.5 MM.

			
ZINC-COATED		989.219.033	500 OR 2.000

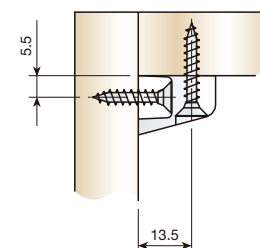

SINGLE-THREAD ASSEMBLY BODY WITH POINTS.

			
ZINC-COATED		550.200.033	1.000

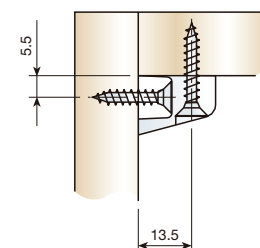

ASSEMBLY BODY SET.

			
WHITE		550.500.005	1000



THE SET HAS 1 COVER, 1 METAL BODY AND 1 FIXING SCREW. THE SET IS SUPPLIED FULLY ASSEMBLED.

3 KNOCK-IN BODIES

ASSEMBLY SCREW WITH TIP M6.

L (MM.)	22	25	
ZINC-COATED	581.322.033	581.325.032	2.000

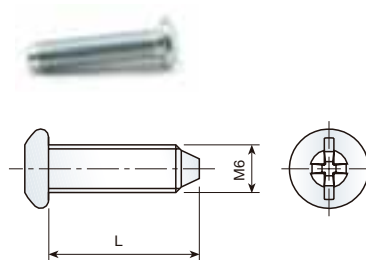

KNOCK-IN BODY.

WHITE	RAL 9003	550.000.006	
BROWIN	RAL 8016	550.000.010	2.000
BLACK	RAL 9005	550.000.021	

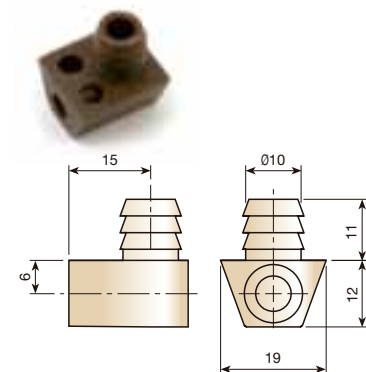

M6 NYLON KNOCK-IN NUT.

NATURAL		937.006.103	
BROWIN	RAL 8016	937.006.011	2.000 ODER 10.000
BLACK	RAL 9005	937.006.022	



M6 STEEL RIBBED KNOCK-IN NUT.

L (MM.)	ZINC-COATED	
14	938.714.103	
16	938.716.100	1.000 OR 5.000
18	938.718.104	
20	938.720.101	

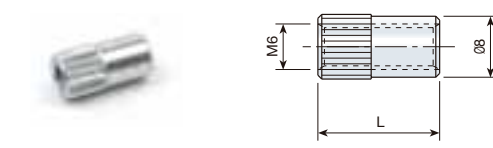

KNOCK-IN BODY SET.

WHITE	550.600.002		2500
-------	-------------	---	------

THE SET HAS 1 KNOCK-IN BODY, 1 KNOCK-IN NUT AND 1 SCREW, AND IT COMES FULLY ASSEMBLED.

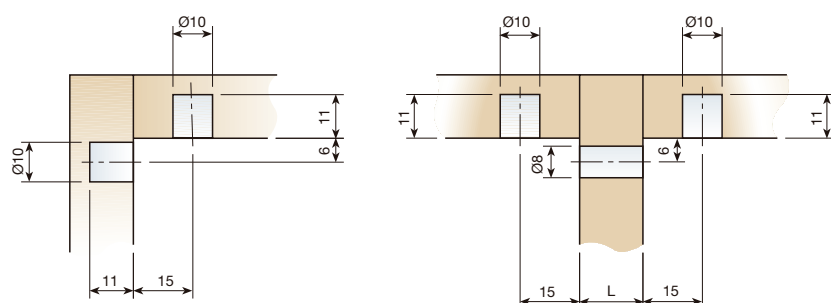

4 SCREWS

ALLEN HEAD FIXING SCREW 5 MM.

L (MM.)	M6	
30	950.730.045	2.000
35	950.735.041	2.000
40	950.740.044	2.000
45	950.745.040	1.000
50	950.750.043	1.000
55	950.755.046	1.000
60	950.760.042	1.000

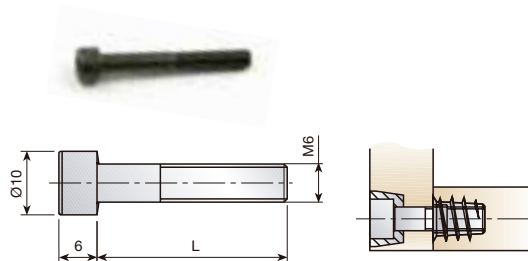

SCREW CAP.

		
BRASS	580.200.106	500 OR 5.000
BLACK ZINC-COATED STEEL	580.200.040	

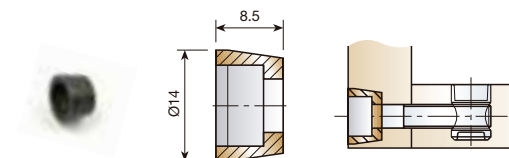

CAPPED FIXING SCREW 1/4".

L (MM.)	BICHROMATED	ZINC-COATED BLACK	
30	953.130.054	953.130.043	2.000
35	953.135.050	953.135.046	2.000
40	953.140.053	953.140.042	2.000
45	953.145.056	953.145.045	1.000
50	953.150.052	953.150.041	1.000
55	953.155.055	953.155.044	1.000
60	953.160.051	953.160.040	1.000
65	953.165.054	953.165.043	1.000

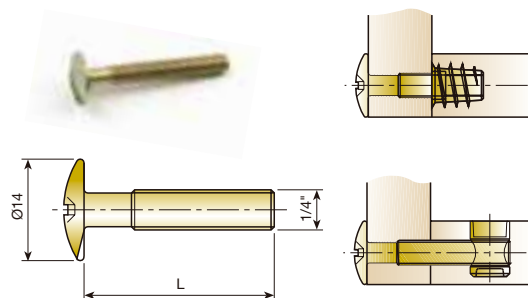

CAP FOR ALLEN SCREW 4 MM.

			
WHITE	RAL 9003	540.500.004	2.000 OR 10.000
BLACK	RAL 9005	540.500.026	
OAK	RAL 1002	540.500.192	

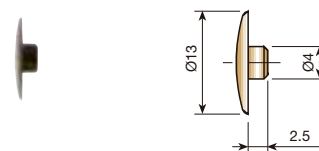

ASSEMBLY SCREW 1/4".

L (MM.)	BLUE	BICHROMATED	
40	581.940.251	581.940.052	2.000
45	581.945.254	581.945.055	2.000
50	581.950.250	581.950.051	2.000
55	581.955.253	581.955.054	1.000

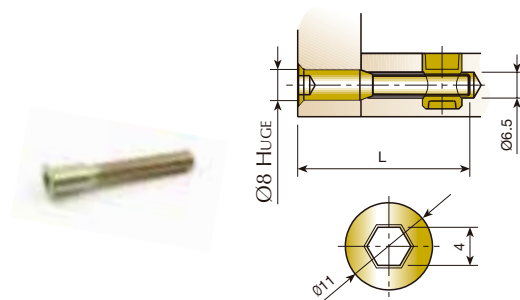

5 NUTS

CYLINDRICAL ZAMAK KNOCK-IN NUT 1/4".

D (MM.)	Ø10		Ø12		
L (MM.)	13 (c=5MM.)	15 (c=6MM.)	13 (c=5MM.)	15 (c=6MM.)	
	940.614.032	940.615.034	940.714.036	940.715.031	2.000

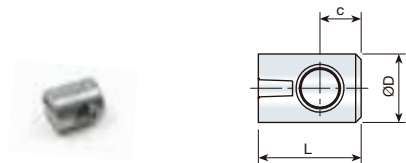

KNURLED NUT M8.

NATURAL	450.008.101	1.000	
---------	-------------	-------	---

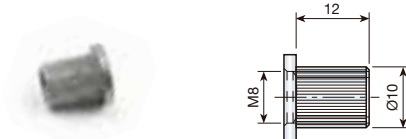

STEEL WOOD-THREADED NUT WITHOUT HEAD.

BICHROMATED					
L (MM.)	Ød (MM.)	ØD (MM.)	1/4"	M6	
10	8	10	947.510.056	947.810.054	2.500
12	8	10	947.512.053	947.812.051	2.000
14	8	10	947.514.050	947.814.055	2.000
18	8	10	947.518.051	947.818.056	2.000
22	8	10	947.522.052	947.822.050	2.000
10	9	12	947.610.053	947.910.051	2.000
12	9	12	947.612.050	947.912.055	2.000
14	9	12	947.614.054	947.914.052	2.000
16	9	12	947.616.051	947.616.051	2.000
18	9	12	947.618.055	947.918.053	2.000

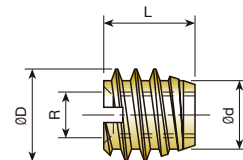

L (MM.)	Ød (MM.)	ØD (MM.)	M8	
22	11	14	948.222.052	1.500

EXPANDING BRASS NUT.

M4	944.805.105	2.000 OR 10.000	
----	-------------	-----------------	---

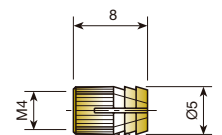

M6 SELF-EXPANDING BRASS NUT.

8 Øx 12 MM.	M6	944.112.105	5.000	
-------------	----	-------------	-------	---

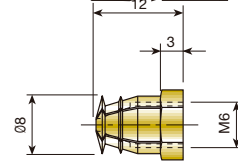

WING NUT

	1/4"	M6	
BICHROMATED		948.913.055	2.000
ZINC-COATED	948.813.036		

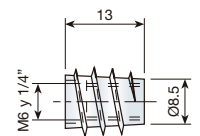

WING NUT WITH HEAD.

	1/4"	M6	M8	
BICHROMATED		948.713.054		2.000
ZINC-COATED	948.613.035		948.515.035	

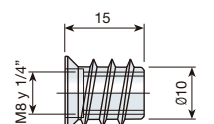
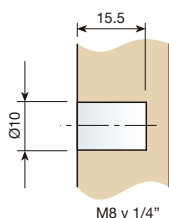
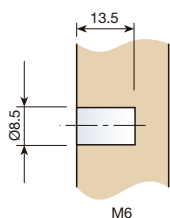
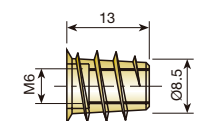

M4 NYLON KNOCK-IN NUT FOR Ø8.

				
NATURAL		937.004.106		2.000 OR 10.000
BROWN	RAL 8016	937.004.014		

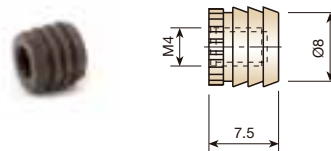

NYLON KNOCK-IN NUT FOR Ø10.

R	M6	1/4"		
NATURAL	937.006.103	937.014.105		2.000 OR 10.000
BROWN	RAL 8016 937.006.011	937.014.013		
BLACK	RAL 9005 937.006.022	937.014.024		

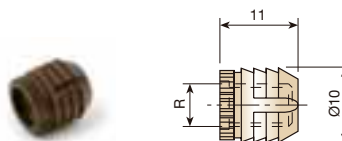

NYLON KNOCK-IN NUT FOR Ø11.

R	M6	1/4"		
NATURAL	937.106.100	937.114.102		2.000 OR 10.000
BROWN	RAL 8016 937.106.015	937.114.010		

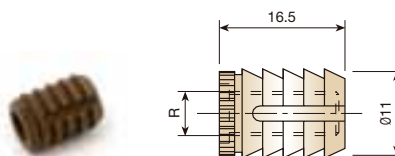

M6 NYLON KNOCK-IN NUT FOR Ø10, IN STRIPS.

				
NATURAL		937.406.105		4.800
BROWN	RAL 8016	937.406.013		
BLACK	RAL 9005	937.014.024		

EVERY BOX CONTAINS 200 STRIPS.
THE STRIPS COME WITH 24 UNITS, AND THEY MAY BE PLACED MANUALLY OR BY MEANS OF A PNEUMATIC GUN WITH CHARGER.

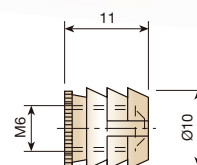

M6 STEEL RIBBED KNOCK-IN NUT.

L	16 MM.	18 MM.		
ZINC-COATED	938.716.100	938.718.104		1.000 OR 5.000

