

Screws and nuts

JOINING ASSEMBLIES

1 SCREWS		<i>pp.</i> 296
<hr/>		
2 SCREWS AND NUTS 297
■ M6 NYLON HEAD	 297
■ M4 STEEL	 297
■ M6 STEEL	 298
■ 1/4" STEEL	 298

1 SCREWS

FIXING SCREW WITH ALLEN HEAD 5 MM.

L (MM.)	M6	
30	950.730.045	2.000
35	950.735.041	2.000
40	950.740.044	2.000
45	950.745.040	1.000
50	950.750.043	1.000
55	950.755.046	1.000
60	950.760.042	1.000

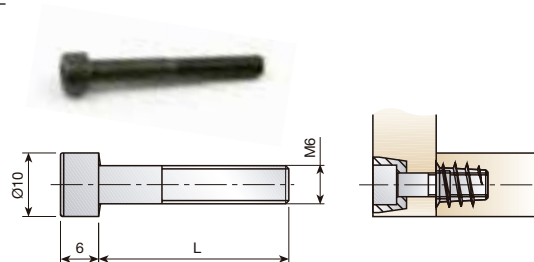

SCREW CAP.

		
BRASS	580.200.106	500 OR 5.000
BLACK ZINC-COATED STEEL	580.200.040	

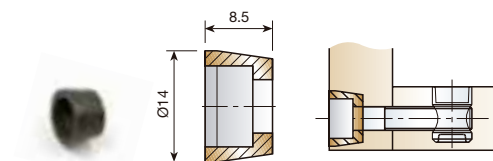

FIXING SCREW WITH CAP 1/4".

L (MM.)	BICHROMATED	ZINC-COATED BLACK	
30	953.130.054	953.130.043	2.000
35	953.135.050	953.135.046	2.000
40	953.140.053	953.140.042	2.000
45	953.145.056	953.145.045	1.000
50	953.150.052	953.150.041	1.000
55	953.155.055	953.155.044	1.000
60	953.160.051	953.160.040	1.000
65	953.165.054	953.165.043	1.000

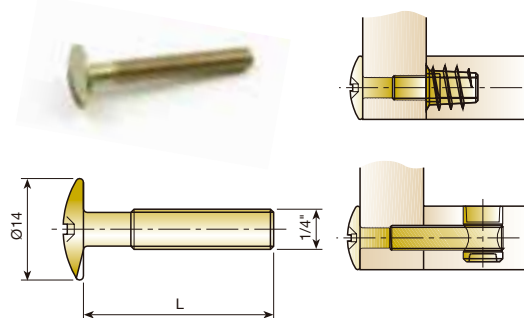

COVER CAP FOR ALLEN SCREW 4 MM.

			
WHITE	RAL 9003	540.500.004	2.000 OR 10.000
BLACK	RAL 9005	540.500.026	
OAK	RAL 1002	540.500.192	

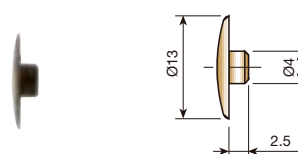

ASSEMBLY SCREW 1/4".

L (MM.)	BLUED	BICHROMATED	
40	581.940.251	581.940.052	2.000
45	581.945.254	581.945.055	2.000
50	581.950.250	581.950.051	2.000
55	581.955.253	581.955.054	1.000

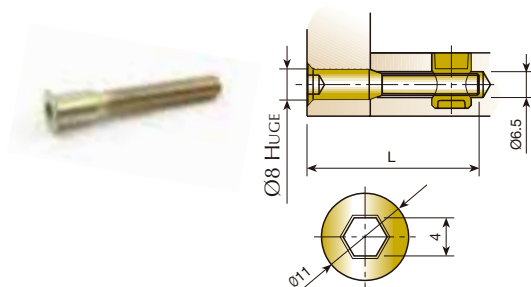

WING NUT WITH HEAD.

	1/4"	M6	
BICHROMATED		948.713.054	2.000
ZINC-COATED	948.613.035		

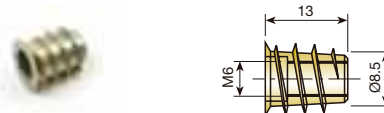

CYLINDRICAL ZAMAK KNOCK-IN NUT 1/4"

D (MM.)	Ø10		Ø12		
L (MM.)	13 (c=5MM.)	15 (c=6MM.)	13 (c=5MM.)	15 (c=6MM.)	2.000
ZINC-COATED	940.614.032	940.615.034	940.714.036	940.715.031	



2 SCREWS AND NUTS

M6 NYLON HEAD

M6 ASSEMBLY SCREW WITH NYLON HEAD AND GROOVE.

L (MM.)	WHITE RAL 9003	BROWN RAL 8016	BLACK RAL 9005	
28	581.028.000	581.028.011	581.028.022	2.000
30	581.030.004	581.030.015	581.030.026	2.000
34	581.034.005	581.034.016	581.034.020	1.000

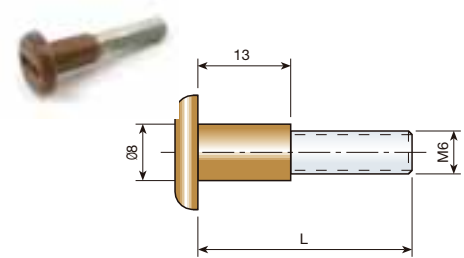

M6 ASSEMBLY SCREW WITH GROOVE.

WHITE	RAL 9003	943.000.004	
BROWN	RAL 8016	943.000.015	1.000 OR 4.000
BLACK	RAL 9005	943.000.026	

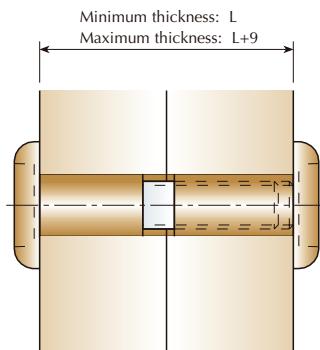
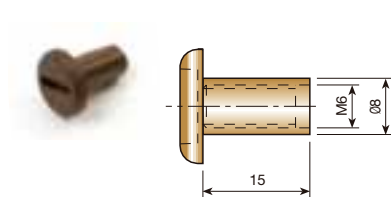

M4 STEEL

M4 STEEL ASSEMBLY SCREW.

L (MM.)	NICKEL-PLATED	
15	941.915.063	3.000
20	941.920.066	2.500
25	941.925.062	2.000
30	941.930.065	2.000
35	941.935.061	2.000
40	941.940.064	2.000
45	941.945.060	1.000

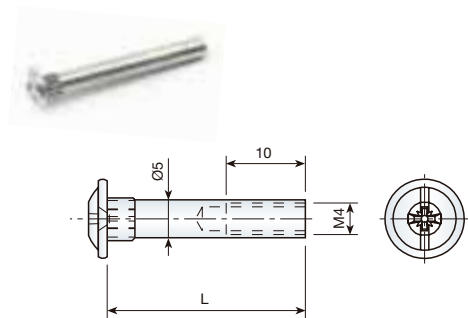

M4 ASSEMBLY SCREW WITH RIDGED HEAD.

NICKEL-PLATED	730.510.060	
		1.000 OR 4.000

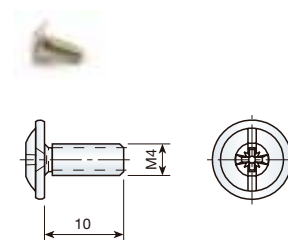
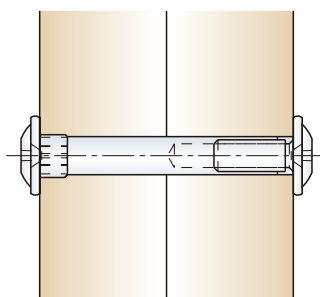

M6 STEEL

M6 STUD BOLT ASSEMBLY NUT.

		
NICKEL-PLATED	942.300.063	1.000 ou 5.000

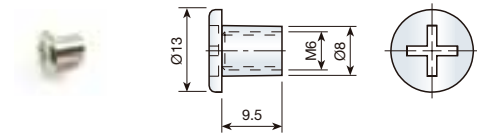

M6 STUD BOLT.

L (MM.)		
30	934.230.102	
35	934.235.105	
45	934.245.104	2.000
50	934.250.100	
60	934.260.106	

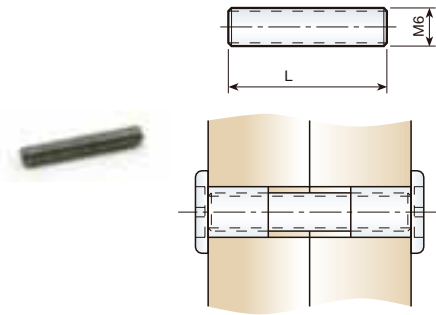

1/4" STEEL

ASSEMBLY SCREW WITH RIDGED HEAD 1/4".

		
NICKEL-PLATED	581.200.060	500 ou 4.000

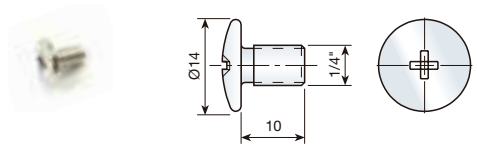

STEEL ASSEMBLY SCREW 1/4.

L (MM.)	ZINC-COATED	
20	941.620.035	2.000
25	941.625.031	2.000
30	941.630.034	2.000
35	941.635.030	2.000
40	941.640.033	2.000
45	941.645.036	1.000
50	941.650.032	1.000
55	941.655.035	1.000
60	941.660.031	1.000
65	941.665.034	1.000
70	941.670.030	1.000
75	941.675.033	500
80	941.680.036	500
85	941.685.032	500
90	941.690.035	500

