

# Accessories

## JOINING ASSEMBLIES

		<i>pp.</i>
<b>1</b>	<b>ACCESSORIES</b> .....	304
■	STOPS .....	304
■	CUSHIONING STOP .....	305
■	CAPS .....	306
■	CASE AND PIVOT .....	308
■	STUD BOLTS .....	308
■	KNOCK-IN NUT AND STAPLE .....	308
■	COUPLING FOR BACK SECTIONS .....	308



# 1 ACCESSORIES

## STOPS

### STOP.

				
WHITE	RAL 9003	919.900.004		
BROWN	RAL 8016	919.900.015	10.000	
BLACK	RAL 9005	919.900.026		

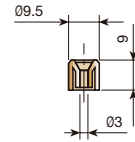

### SUPPORT STOP FOR LEGS.

				
BLACK	RAL 9005	420.000.022	5.000	

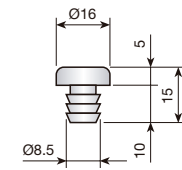

### CHAIR STOP WITH NAIL Ø16.

				
WHITE	RAL 9003	420.100.004		
BROWN	RAL 8016	420.100.015	5.000	
BLACK	RAL 9005	420.100.026		

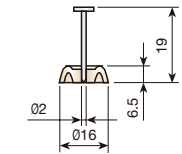

### CHAIR STOP WITH NAIL, LARGE.

				
WHITE	RAL 9003	420.200.001		
BROWN	RAL 8016	420.200.012	5.000	
BLACK	RAL 9005	420.200.023		

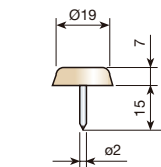

### STOP WITH TWO NAILS, SMALL.

				
WHITE	RAL 9003	420.300.005		
BROWN	RAL 8016	420.300.016	5.000	
BLACK	RAL 9005	420.300.020		

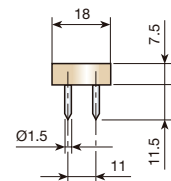

### STOP WITH TWO NAILS, LARGE.

				
WHITE	RAL 9003	420.400.002		
BROWN	RAL 8016	420.400.013	5.000	
BLACK	RAL 9005	420.400.024		

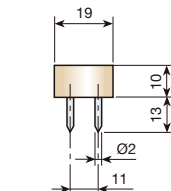

**CUSHIONING STOP**

CUSHIONING STOP "BALÍN".

			
WHITE	RAL 9003	930.100.006	
BROWN	RAL 8016	930.100.010	5.000
OAK	RAL 1002	930.100.194	

IT COMES IN STRIPS OF 50 STOPS, TO BE FIXED USING A PNEUMATIC GUN WITH CHARGER.



PNEUMATIC GUN.

			
		900.000.102	1

TECHNICAL FEATURES:  
-WEIGHT: 1KG.  
-PRESSURE: 5 TO 6 ATMS.  
-CHARGING CAPACITY: 50 STOPS OF Ø 10 MM.



RUBBER CUSHIONING STOP.

			
TRANSPARENT		930.505.100	5.000

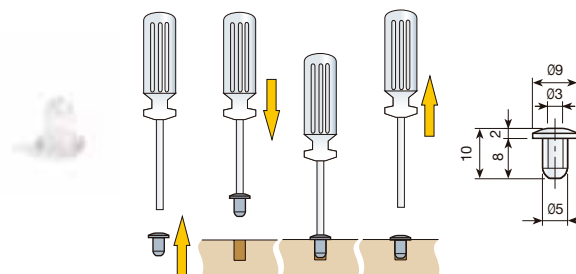

CUSHIONING STOP SYSTEM 32.

			
WHITE		930.637.002	4.000

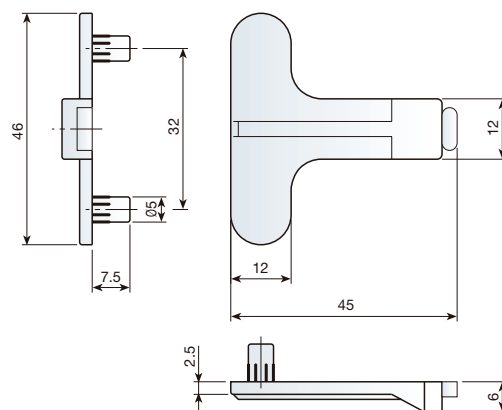
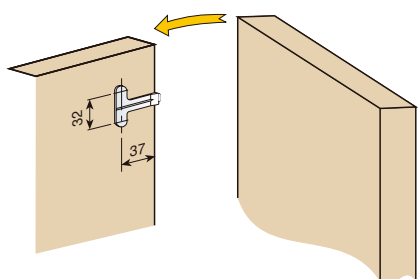

■ CAPS

CAP Ø4.

HEAD Ø13.				
WHITE	RAL 9003		540.500.004	
BROWN	RAL 8016		540.500.015	10.000
BLACK	RAL 9005		540.500.026	

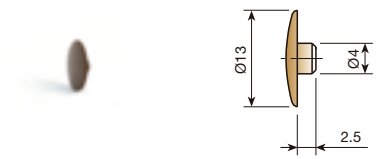

CAP Ø5.

HEAD Ø12.				
WHITE	RAL 9003		960.000.005	
BROWN	RAL 8016		960.000.016	10.000
BLACK	RAL 9005		960.000.020	

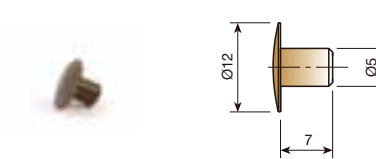

CAP Ø8.

				
NICKEL-PLATED		HEAD Ø10	960.300.062	3.000
WHITE	RAL 9003	HEAD Ø12	960.300.003	
BROWN	RAL 8016	HEAD Ø12	960.300.014	10.000
BLACK	RAL 9005	HEAD Ø12	960.300.025	

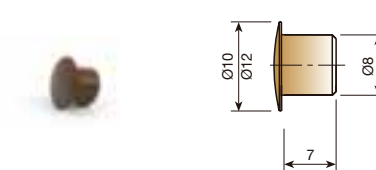

CAP Ø10.

HEAD Ø12.				
NICKEL-PLATED			960.700.064	3.000
WHITE	RAL 9003		960.700.005	
BROWN	RAL 8016		960.700.016	10.000
BLACK	RAL 9005		960.700.020	

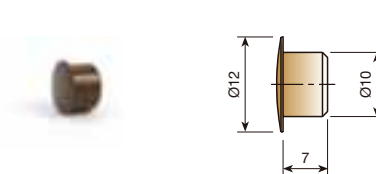

■ CAPS

CAP Ø12.

HEAD Ø15.			
WHITE	RAL 9003	961.000.003	
BROWN	RAL 8016	961.000.014	10.000
BLACK	RAL 9005	961.000.025	

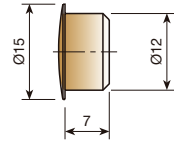

CAP Ø15.

HEAD Ø17.			
NICKEL-PLATED		961.200.063	3.000
WHITE	RAL 9003	961.200.004	
BROWN	RAL 8016	961.200.015	10.000
BLACK	RAL 9005	961.200.026	

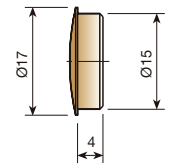

CAP Ø25.

HEAD Ø28,5.			
WHITE	RAL 9003	530.400.006	
BROWN	RAL 8016	530.400.010	2.000
BLACK	RAL 9005	530.400.021	

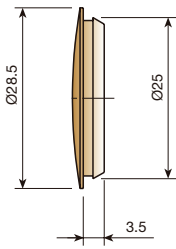

CAP Ø35.

HEAD Ø39.			
NICKEL-PLATED		530.500.062	
WHITE	RAL 9003	530.500.003	1.000
BROWN	RAL 8016	530.500.014	
BLACK	RAL 9005	530.500.025	

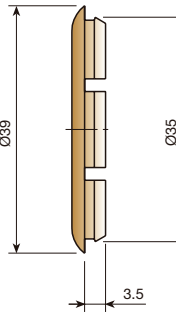

**CASE AND PIVOT**

**KNOCK-IN CENTERING CASE.**

				
BROWN	RAL 8016	918.000.016	5.000	
BLACK	RAL 9005	918.000.020		

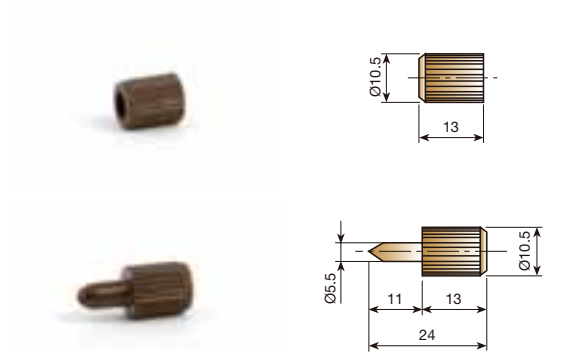

**KNOCK-IN CENTERING PIVOT.**

				
BROWN	RAL 8016	918.000.013	5.000	
BLACK	RAL 9005	918.000.024		

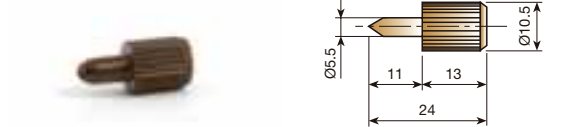

**STUD BOLTS**

**TWIN-THREAD STUD BOLT.**

LENGTH	1/4"	M6	
50	934.450.031	934.550.035	
60	934.460.030	934.560.034	1.000
80	934.480.035	934.580.032	

LENGTH	5/16"	M8	
50	934.650.032	934.750.036	1.000
60	934.660.031	934.760.035	1.000
80	934.680.036	934.780.033	500



**KNOCK-IN STAPLE AND NUT**

**STAPLE**

				
ZINC-COATED		914.000.032	10.000	

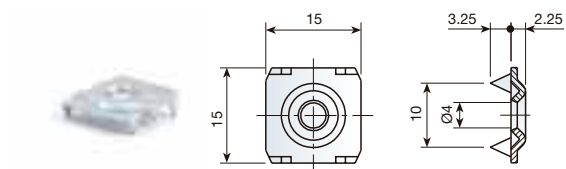

**KNOCK-IN FORKED NUT.**

LENGTH	THREAD		
7	M4	938.004.034	4.000
7	M5	938.005.036	2.500
8,5	M6	938.106.035	2.500
11	M8	938.208.036	1.500
12	M10	938.410.034	1.000

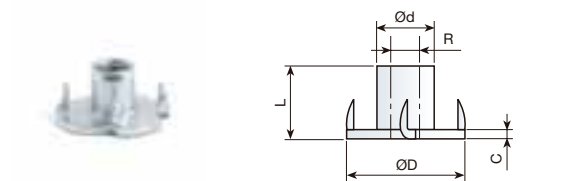

R	ØD	Ød	L	C
M4	15	5	7	1
M5	16	6,5	7	1
M6	18	8	8,5	1,5
M8	22	9,5	11	1,75
M10	26	12	12	1,75

**COUPLING FOR BACK SECTIONS**

**COUPLING FOR BACK OF CABINET**

				
	NICKEL-PLATED	519.015.066	1.000	

