



"GACELA" roller runners

		<i>pp.</i>
1	"GACELA"	374
	■ "GACELA" RUNNERS	374
	■ ADJUSTABLE	375
	■ FOR DOWEL-FIX DRAWER ASSEMBLY	376
	■ QUICK ASSEMBLY	377
	■ WITH ADJUSTABLE FRONT	378
	■ FOR DROP-DOWN FRONT	379
<hr/>		
2	"GACELA-3"	380
	■ "GACELA-3" RUNNERS	380
	■ FOR DOWEL-FIX DRAWER ASSEMBLY	381

1 "GACELA"

"GACELA" RUNNERS

SELF-CLOSING "GACELA" RUNNER

LOAD	LENGTH	WHITE RAL 9001	BLACK RAL 9005	EXT. LOSS	
250 N. (25 KP.)	250	760.025.803	760.025.825	59	100
	300	760.030.806	760.030.821	68	
	350	760.035.802	760.035.824	77	
	400	760.040.805	760.040.820	86	
	450	760.045.801	760.045.823	95	
	500	760.050.804	760.050.826	104	
	550	760.055.800	760.055.822	113	
	600	760.060.803	760.060.825	122	
	700*	760.070.802	760.070.824	140	
	800*	760.080.801	760.080.823	158	

IN THESE REFERENCES, THE 4 PROFILES ARE PACKED SEPARATELY IN BOXES OF 100 UNITS. 700 AND 800 LENGTHS COME IN 4 BOXES OF 50 UNITS.



"GACELA" RUNNER: SETS.

LOAD	LENGTH	WHITE RAL 9001	BLACK RAL 9005	EXT. LOSS	
250 N. (25 KP.)	250	760.125.800	760.125.822	59	30
	300	760.130.803	760.130.825	68	
	350	760.135.806	760.135.821	77	
	400	760.140.802	760.140.824	86	
	450	760.145.805	760.145.820	95	
	500	760.150.801	760.150.823	104	

IN THESE REFERENCES, THE 4 PROFILES ARE PACKED TOGETHER IN BOXES OF 30 SETS.
MINIMUM ORDER: 300 SETS.

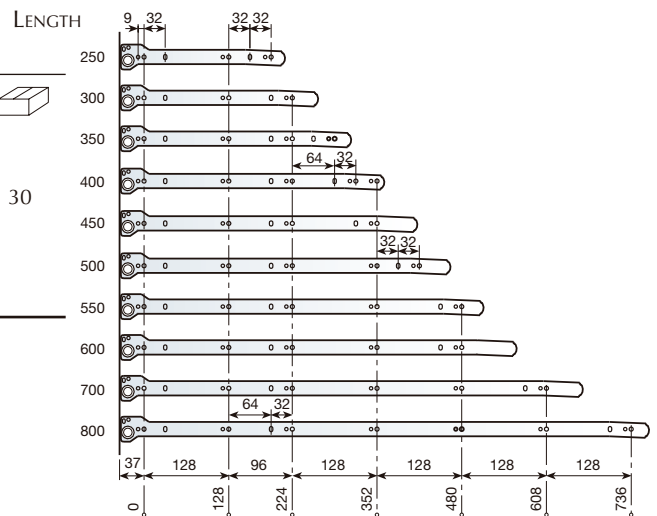

EURO-SCREW

	Ø7	Ø7.75	
NICKEL-PLATED	952.810.062	953.610.066	5.000

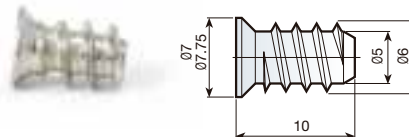

Assembly

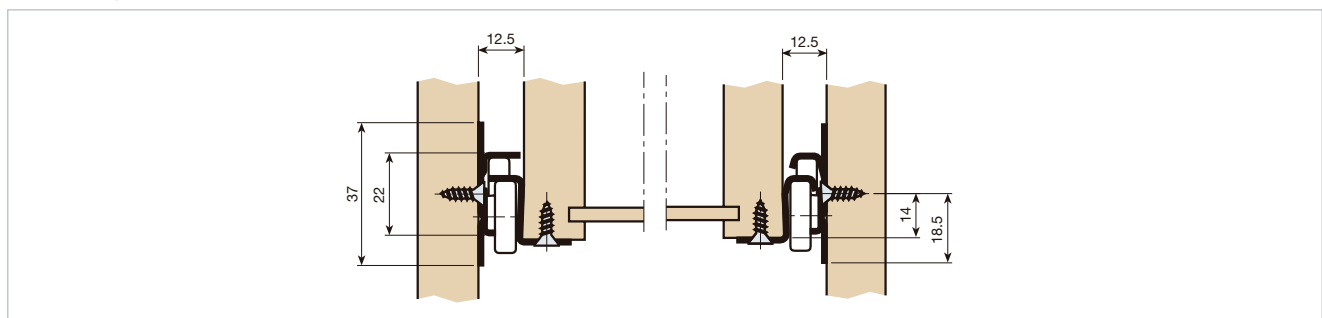

■ "GACELA" ADJUSTABLE RUNNER

"GACELA" RUNNER, PIN FIXING

LOAD	LENGTH	WHITE RAL 9001	BLACK RAL 9005	EXT. LOSS PS	EXTENSION DC	
250 N. (25 KP.)	250	759.525.804	759.525.826	59	128	100
	300	759.530.800	759.530.822	68	160	
	350	759.535.803	759.535.825	77	224	
	400	759.540.806	759.540.821	86	256	
	450	759.545.802	759.545.824	95	288	
	500	759.550.805	759.550.820	104	320	

IN THESE REFERENCES, THE 4 PROFILES ARE PACKED SEPARATELY IN BOXES OF 100 UNITS. A 10MM KEY IS AVAILABLE FOR ADJUSTMENTS. REF.: 700.500.102.



"GACELA" RUNNER, SCREW-ON FIXING

LOAD	LENGTH	WHITE RAL 9001	BLACK RAL 9005	EXT. LOSS PS	EXTENSION DC	
250 N. (25 KP.)	250	759.025.805	759.025.820	59	128	100
	300	759.030.801	759.030.823	68	160	
	350	759.035.804	759.035.826	77	224	
	400	759.040.800	759.040.822	86	256	
	450	759.045.803	759.045.825	95	288	
	500	759.050.806	759.050.821	104	320	

IN THESE REFERENCES, THE 4 PROFILES ARE PACKED SEPARATELY IN BOXES OF 100 UNITS. A 10MM KEY IS AVAILABLE FOR ADJUSTMENTS REF. 700.500.102.



Assembly

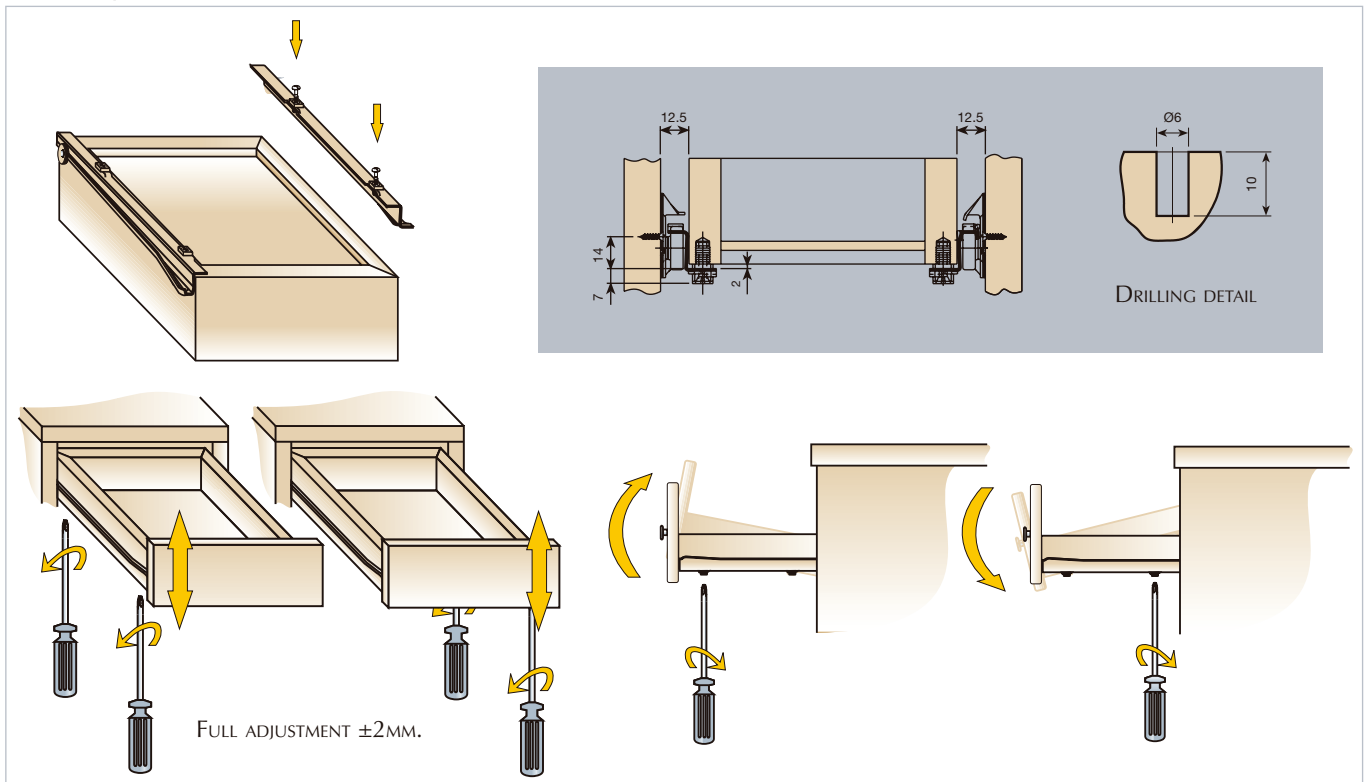

■ "GACELA" RUNNER FOR DOWEL-FIX DRAWER ASSEMBLY

"GACELA" RUNNER FOR DOWEL-FIX DRAWER ASSEMBLY.

LOAD	LENGTH	WHITE RAL 9001	BLACK RAL 9005	EXT. LOSS	
250 N. (25 KP.)	250	760.725.803	760.725.825	59	100
	300	760.730.806	760.730.821	68	
	350	760.735.802	760.735.824	77	
	400	760.740.805	760.740.820	86	
	450	760.745.801	760.745.823	95	
	500	760.750.804	760.750.826	104	

IN THESE REFERENCES, THE 4 PROFILES ARE PACKED SEPARATELY IN BOXES OF 100 UNITS.

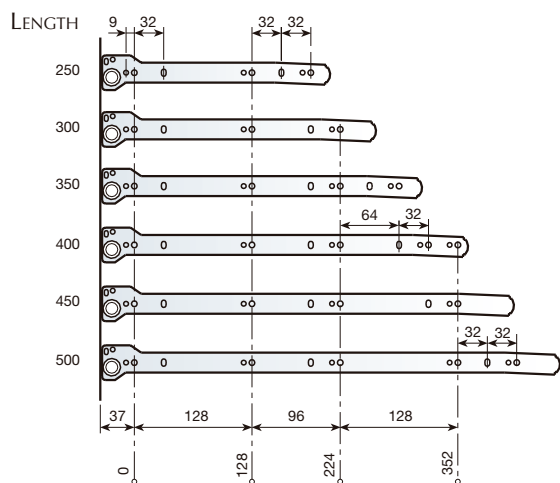

"GACELA" CRIMPING TOOL

	
751.300.104	1

THIS IS A SIMPLE PNEUMATIC TOOL WHICH FIXES THE RUNNER TO THE DRAWER BETWEEN TWO CLAMPS. THE TOOL COMES AUTOMATICALLY WITH SPRING LOADED HANGING DEVICE FOR EASY ACCESS.

ASSEMBLY: TURN THE DRAWER UPSIDE DOWN AND PLACE THE RUNNER ON THE DRAWER SIDE. PLACE THE CLAMPS OF THE TOOL OVER EACH SET OF CLIPS AND PRESS THE BUTTON.

Assembly

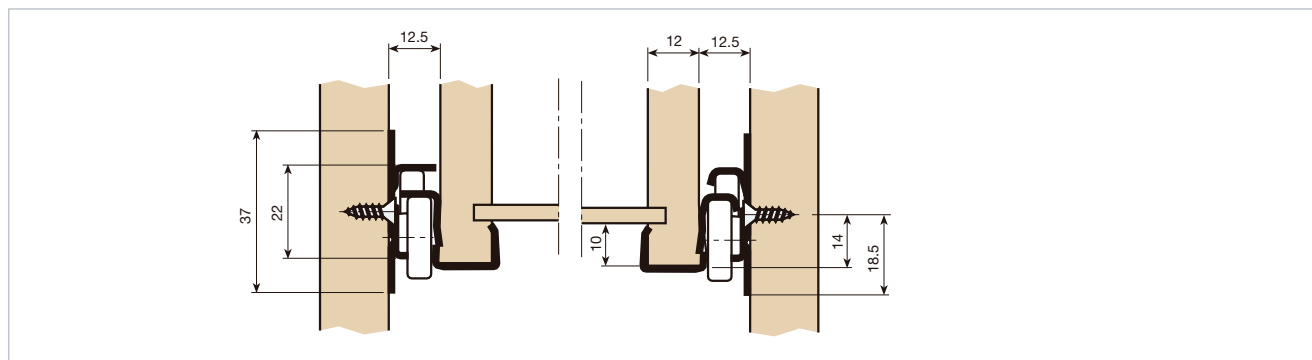

■ "GACELA" QUICK ASSEMBLY RUNNERS

"GACELA" QUICK ASSEMBLY RUNNER.

LOAD	LENGTH	DRAWER	WHITE RAL 9001	C	LOSS OF EXTENSION PS	
	350	330	760.235.803	303	77	
250 N. (25 kp.)	400	380	760.240.806	353	86	100
	450	430	760.245.802	403	95	
	500	480	760.250.805	453	104	

IN THESE REFERENCES, THE 4 PROFILES ARE PACKED SEPARATELY IN BOXES OF 100 UNITS.

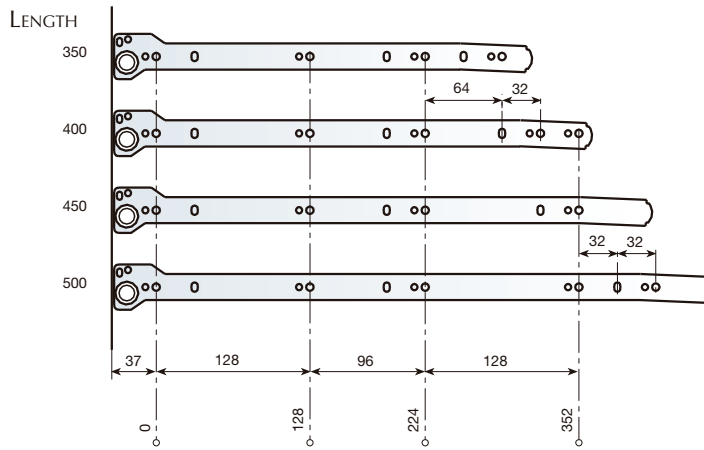

Assembly

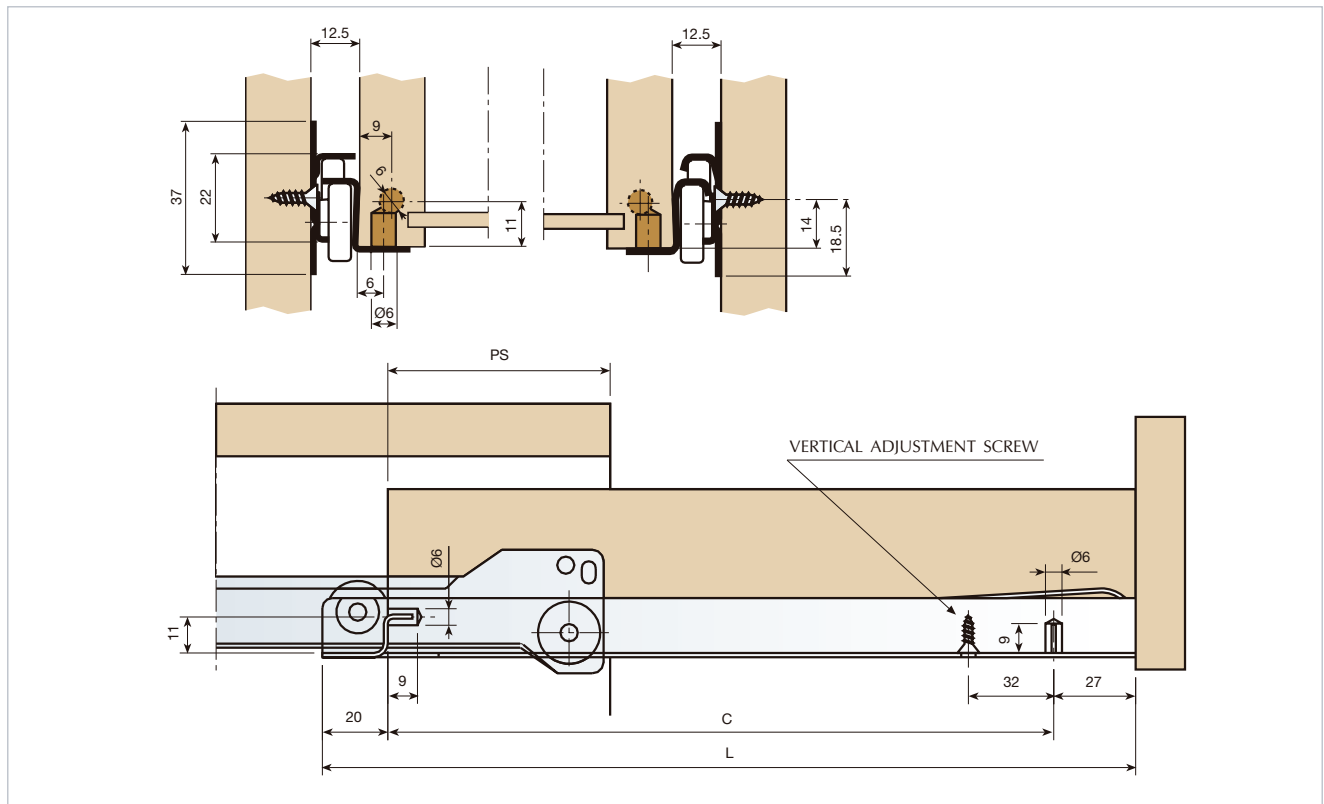

■ "GACELA" RUNNERS WITH ADJUSTABLE FRONT

"GACELA" RUNNERS WITH ADJUSTABLE FRONT.

LOAD	LENGTH	WHITE RAL 9001	EXT. LOSS	
250 N. (25 kp.)	450	760.345.806	95	100
	500	760.350.802	104	

SUPPLIED WITH WASHERS AND FIXING SCREWS.

IN THESE REFERENCES, THE PROFILES ARE PACKED SEPARATELY: Z PROFILES IN BOXES OF 50 AND U PROFILES IN BOXES OF 100.

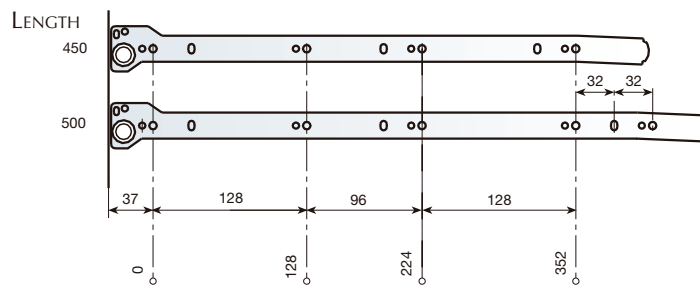

Assembly

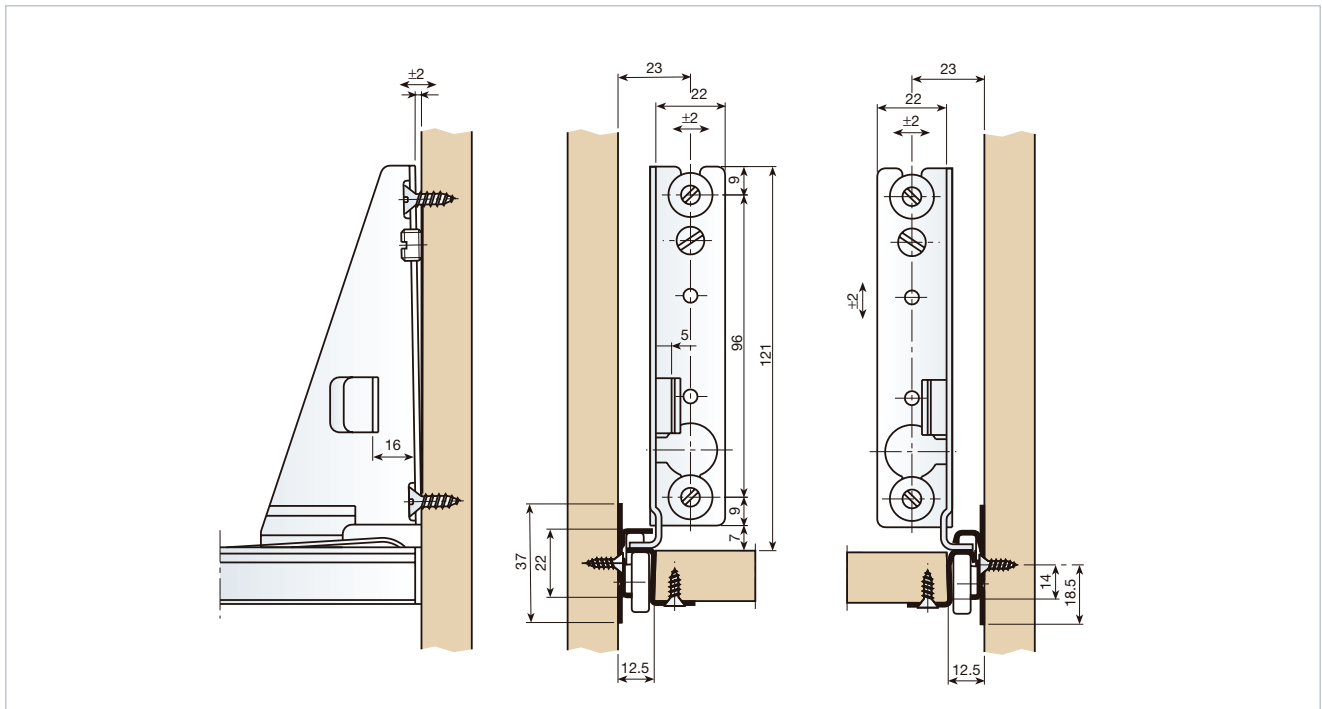

■ "GACELA" RUNNERS FOR DROP-DOWN FRONT

"GACELA" WITH FITTING FOR DROP-DOWN FRONT.

LOAD	LENGTH	WHITE RAL 9001	EXTENSION LOSS PS	
250 N. (25 kp.)	450	759.745.803	95	100
	500	759.750.806	104	

IN THESE REFERENCES, THE 4 PROFILES ARE PACKED SEPARATELY IN BOXES OF 100 UNITS.

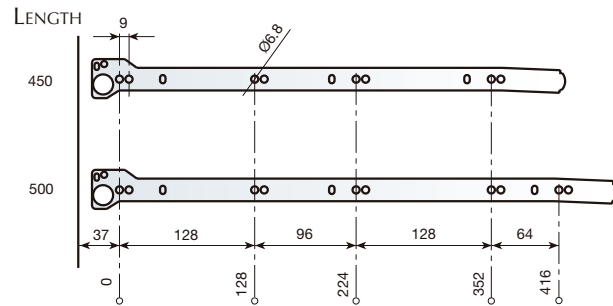

Assembly

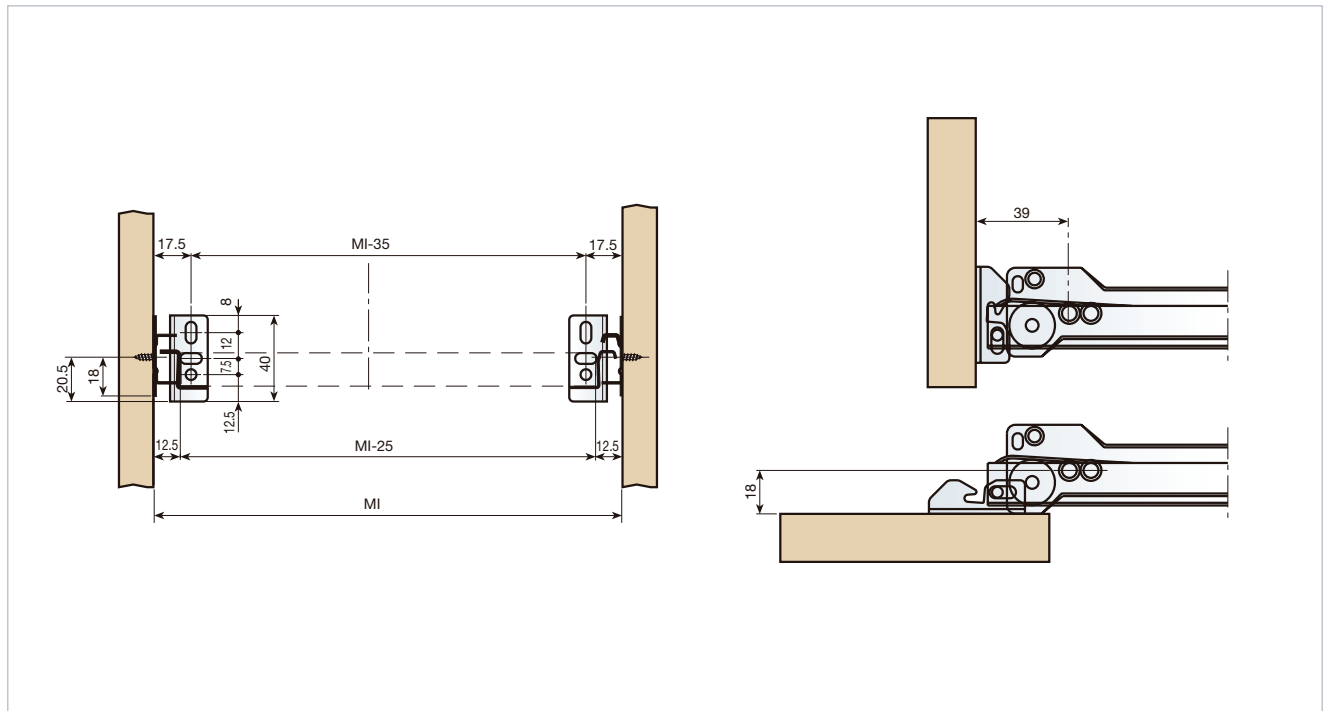

2 "GACELA-3"

"GACELA-3" RUNNER

"GACELA-3" RUNNER: SCREW-FIX ASSEMBLY.

LOAD	LENGTH	WHITE RAL 9001	BLACK RAL 9005	EXTENSION LOSS PS	
250 N. (25 KP.)	300	755.030.006	755.030.021	85	100
	350	755.035.002	755.035.024	85	
	400	755.040.005	755.040.020	85	
	450	755.045.001	755.045.023	95	
	500	755.050.004	755.050.026	102	
	550	755.055.000	755.055.022	109	
	600	755.060.003	755.060.025	119	

IN THESE REFERENCES, THE 4 PROFILES ARE PACKED SEPARATELY IN BOXES OF 100 UNITS.

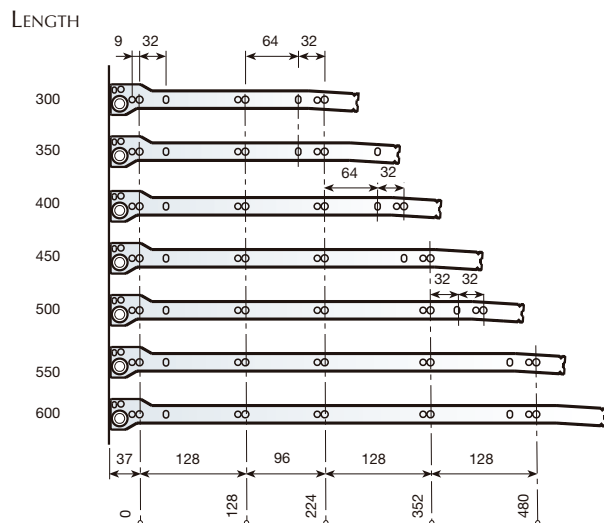

Assembly

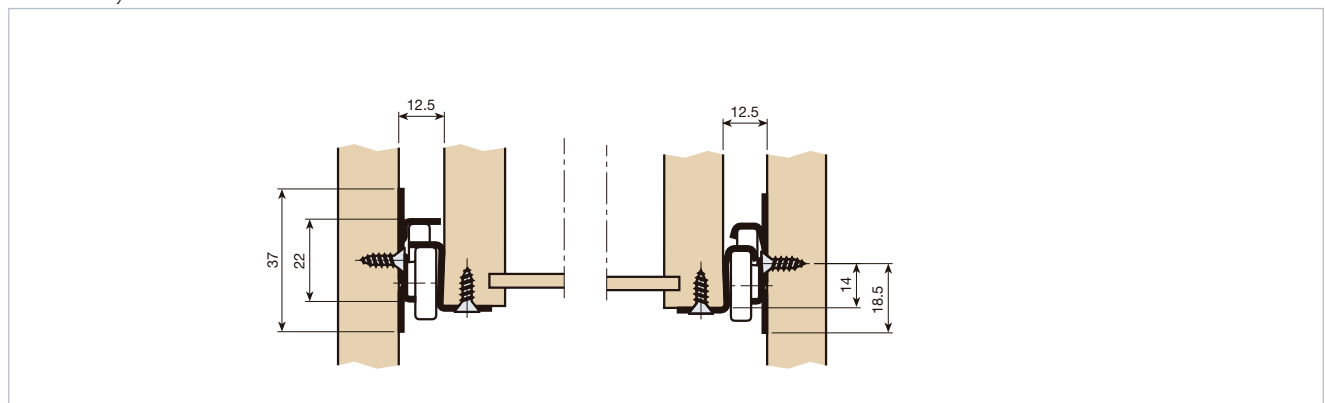

■ "GACELA-3" RUNNER FOR DOWEL-FIX DRAWER ASSEMBLY

"GACELA-3" RUNNER FOR DOWEL-FIX DRAWER ASSEMBLY

LOAD	LENGTH	WHITE RAL 9001	BLACK RAL 9005	EXTENSION LOSS PS	
250 N. (25 KP.)	250	755.225.004	755.225.026	85	100
	300	755.230.000	755.230.022	85	
	350	755.235.003	755.235.025	85	
	400	755.240.006	755.240.021	85	
	450	755.245.002	755.245.024	95	
	500	755.250.005	755.250.020	102	
	550	755.255.001	755.255.023	109	
	600	755.260.004	755.260.026	119	

IN THESE REFERENCES THE PROFILES ARE PACKED SEPARATELY IN BOXES OF 100 UNITS.

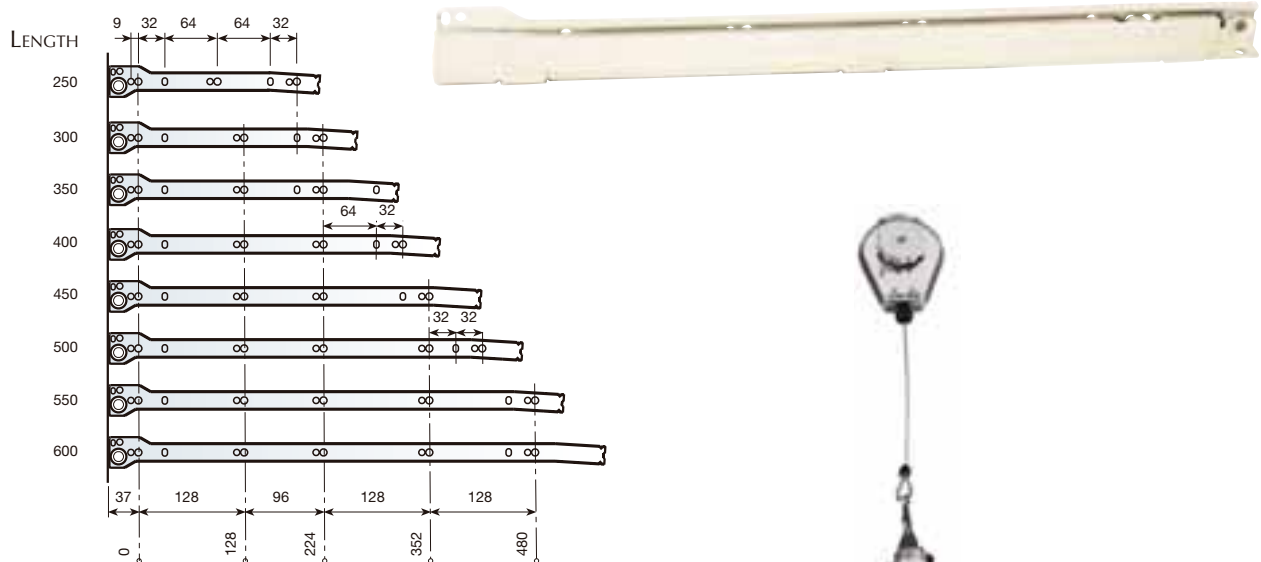

"GACELA" CRIMPING TOOL

	751.300.104	1
---	-------------	---

THIS IS A SIMPLE PNEUMATIC TOOL WHICH FIXES THE RUNNER TO THE DRAWER BETWEEN TWO CLAMPS. THE TOOL COMES AUTOMATICALLY WITH SPRING LOADED HANGING DEVICE FOR EASY ACCESS. ASSEMBLY: TURN THE DRAWER UPSIDE DOWN AND PLACE THE RUNNER ON THE DRAWER SIDE. PLACE THE CLAMPS OF THE TOOL OVER EACH SET OF CLIPS AND PRESS THE BUTTON.

Assembly

