



“INDAUX” drawer

“INDAUX” drawer

1 DRAWER FOR MARC RUNNER		<i>pp.</i> 485
2 DRAWER FOR GACELA RUNNER	 486
3 PAN DRAWER ACCESSORIES	 487
4 CUTLERY TRAY	 488

1 DRAWER FOR MARC RUNNER

"INDAUX" DRAWER WITHOUT WINDOW FOR "MARC" RUNNER.

MODULE	WHITE RAL 9001	BEIGE RAL 1015	
300	681.830.004	681.830.461	10
350	681.835.000	681.835.464	
400	681.840.003	681.840.460	
450	681.845.006	681.845.463	
500	681.850.002	681.850.466	
600	681.860.001	681.860.465	



"MARC" CONCEALED RUNNER WITH PRE-MOUNTED SELF-CLOSING DEVICE.

LENGTH	EXTENSION LOSS	REFERENCE	REFERENCE	
		15÷16 MM.SIDE	18÷19 MM.SIDE	20
430	90	765.143.035	766.243.030	
480	60	765.148.031	766.248.033	



ACCURATE AND SILENT GUIDING WITH PRECISION ROLLERS FOR HEAVY DUTY OPERATION.

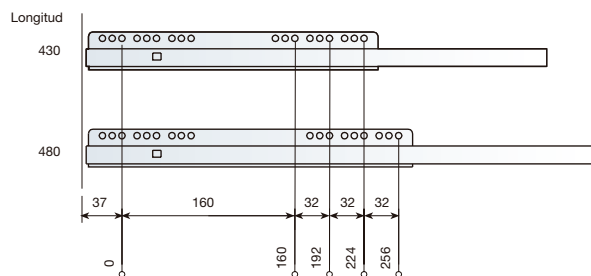
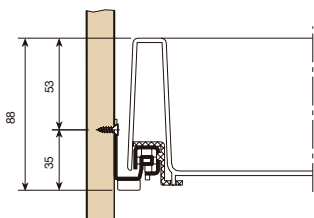

DRAWER FRONT FIXING BRACKET.

SCREW-FIXED ASSEMBLY	685.600.031	200	
----------------------	-------------	-----	---

REFERENCE CONSISTS OF A COMPLETE SET OF FRONT BRACKETS.



MODULE	F
300	181
350	231
400	281
450	331
500	381
600	481

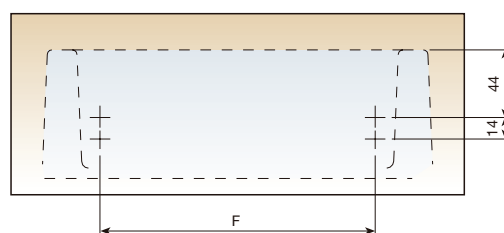

2 DRAWER FOR GACELA RUNNER

"INDAUX" DRAWER FOR "GACELA" RUNNER.

MODULE	WHITE RAL 9001	BEIGE RAL 1015	
300	680.230.003	680.230.460	10
350	680.235.006	680.235.463	
400	680.240.002	680.240.466	
450	680.245.005	680.245.462	
500	680.250.001	680.250.465	
600	680.260.000	680.260.464	



DRAWER RUNNER FOR UNITS WITH 15÷16 MM END PANEL.

L	EXTENSION LOSS PS	WHITE RAL 9001	BEIGE RAL 1015	
430	77	789.543.801	789.543.860	100
480	35	789.548.804	789.548.863	



DRAWER RUNNERS FOR UNITS WITH 18÷19 MM END PANEL.

L	EXTENSION LOSS PS	WHITE RAL 9001	BEIGE RAL 1015	
430	77	789.643.805	789.643.864	100
480	35	789.648.801	789.648.860	

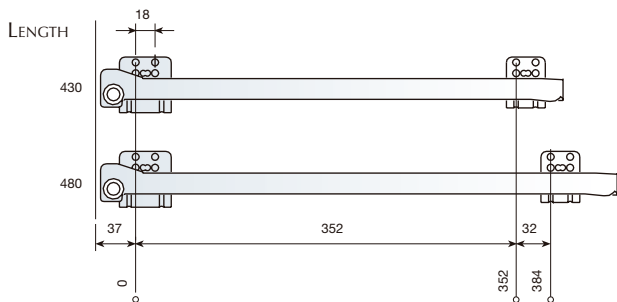
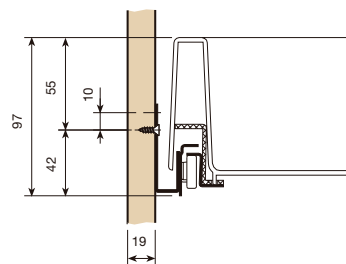
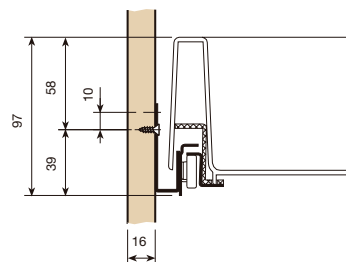

FRONT FIXING BRACKET.

SCREW-FIXED ASSEMBLY	685.600.031	
		200

REFERENCE CONSISTS OF A COMPLETE SET OF BRACKETS.



MODULE	F
300	181
350	231
400	281
450	331
500	381
600	481

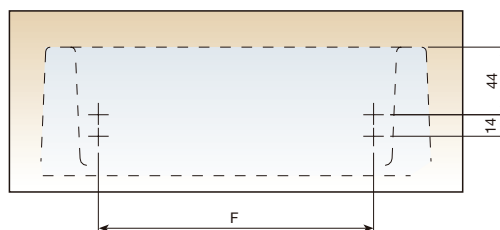

3 PAN DRAWER ACCESSORIES

OUTER FRAME FOR "INDAUX" DRAWER.

MODULE	L	CHROME-PLATED	
300	230	745.130.120	20
350	280	745.135.123	
400	330	745.140.126	
450	380	745.145.122	
500	430	745.150.125	
600	530	745.160.124	

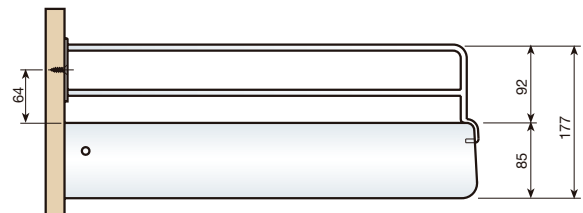
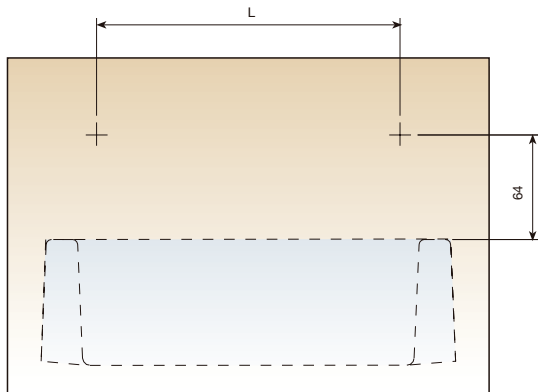
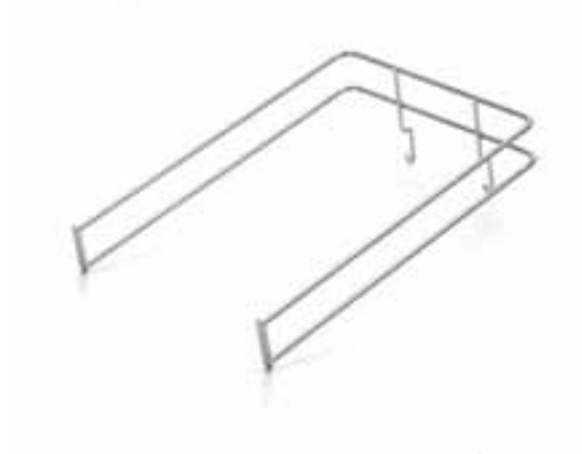

4 CUTLERY TRAY

SPECIALLY DESIGNED FOR "INDAUX" DRAWER. AVAILABLE IN TWO VERSIONS: ADJUSTED TO EVERY MODULE FROM 300 TO 600 AND WITH LATERAL FLAP, ADAPTABLE TO MODULES FROM 350 AND FROM 450. INJECTION MOULDED WITH A VERY RESISTANT IMPACTPROOF MATERIAL, OBTAINING VERY UNIFORM AND STRONG WALLS.

"INDAUX" CUTLERY TRAY.

MODULE	WHITE RAL9001	BEIGE RAL 1015	MEASUREMENTS			
			LENGTH	WIDTH	HEIGHT	
300	687.130.006	687.130.463	391	206	45	25
350	689.035.001	689.035.465	391	256	45	20
400	687.140.005	687.140.462	391	306	45	25
450	689.045.000	689.045.464	391	356	45	20
500	689.050.003	689.050.460	391	406	45	20
600	689.060.002	689.060.466	391	506	45	20

WITHOUT FLAP. ADJUSTABLE TO ANY DRAWER MODULE.



"INDAUX" CUTLERY TRAY, MODELS 350 AND 450.

MODULE	WHITE RAL9001	BEIGE RAL 1015	
350	687.035.005	687.035.462	25
450	687.045.004	687.045.461	25

CUTLERY TRAYS WITH LATERAL FLAP FOR DRAWER MODULES FROM 350 AND 450.

