

Glass cabinet doors

pp.

1	MACHINED GLASS CABINETS AND UNMACHINED PROFILES	670
	■ 20X20 1MM RADIUS	
	<i>Machined glass cabinets</i>	670
	<i>Profile to be machined</i>	671
	■ 20X20 6MM RADIUS	
	<i>Machined glass cabinets</i>	672
	<i>Profile to be machined</i>	673
	■ 20X20 1MM RADIUS, 7.5MM VISIBLE	
	<i>Machined glass cabinets</i>	674
	<i>Profile to be machined</i>	675
	■ 35X20 1MM RADIUS, 7.5MM VISIBLE	
	<i>Machined glass cabinets</i>	676
	<i>Profile to be machined</i>	677
	■ 45X20 1MM RADIUS, 7.5MM VISIBLE	
	<i>Machined glass cabinets</i>	678
	<i>Profile to be machined</i>	679
	■ 45X20 1.2 VISIBLE	
	<i>Machined glass cabinets</i>	680
	<i>Profile to be machined</i>	681
	■ 45X20X20 VISIBLE	
	<i>Machined glass cabinets</i>	682
	<i>Profile to be machined</i>	683
	■ 50X20X7.5 VISIBLE	
	<i>Machined glass cabinets</i>	684
	<i>Profile to be machined</i>	685
2	UNMACHINED: "SCREEN KIT"	686

1 MACHINED GLASS CABINETS

20X20 1MM RADIUS

STANDARD KITCHEN

GLASS CABINET 20x20 1MM RADIUS.

MODULE	DIM. GLASS 4MM.	ANOD. SILVER MATT	ANOD. STAINLESS STEEL	
70x30 (698x298)	671x271	143.130.514	143.130.562	1
70x35 (698x348)	671x321	143.135.510	143.135.565	
70x40 (698x398)	671x371	143.140.513	143.140.561	
70x45 (698x448)	671x421	143.145.516	143.145.564	
70x50 (698x498)	671x471	143.150.512	143.150.560	
70x60 (698x598)	671x571	143.160.511	143.160.566	
90x30 (898x298)	871x271	143.330.515	143.330.563	
90x35 (898x348)	871x321	143.335.511	143.335.566	
90x40 (898x398)	871x371	143.340.514	143.340.562	
90x45 (898x448)	871x421	143.345.510	143.345.565	
90x50 (898x498)	871x471	143.350.513	143.350.561	
90x60 (898x598)	871x571	143.360.512	143.360.560	

SUPPLIED MACHINED AND DISMANTLED, WITH THE JOINING FITTINGS AND THE GASKETS FOR 4MM GLASS. IN BOXES OF 1 DOOR.

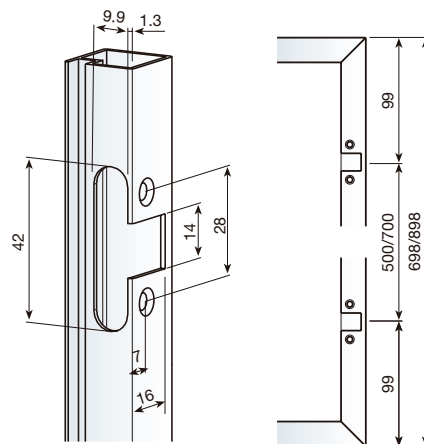
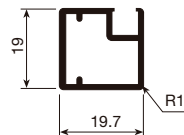

MACHINING AND LOCATION OF HINGES

MADE TO MEASURE

GLASS CABINET 20x20 R1 TO MEASURE.

PROFILE	HINGES	ANOD. SILVER MAT	ANOD. STAINLESS STEEL	
20x20R1	0	143.100.510	143.102.565	1
20x20R1	2	143.102.514	143.102.562	
20x20R1	3	143.103.516	143.103.564	
20x20R1	4	143.104.511	143.104.566	

NOTE

THE POSITION OF THE HINGES IS CALCULATED FROM THE INSIDE OF THE CABINET (MACHINING SIDE). THIS SHOULD BE TAKEN INTO ACCOUNT IN THE CASE OF ASYMMETRIC DOORS. MACHINING FOR 2 HINGES.

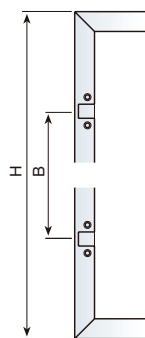

MACHINING FOR 2 HINGES

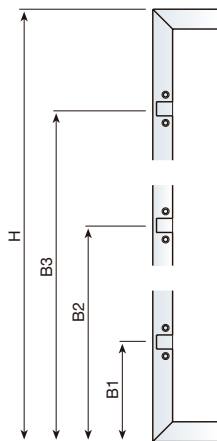

MACHINING FOR 3 HINGES

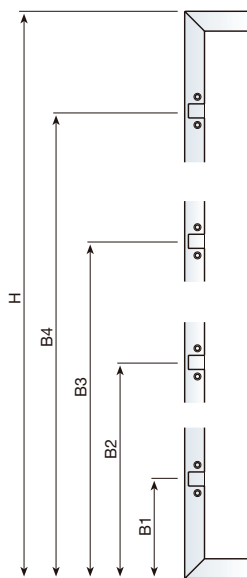

MACHINING FOR 4 HINGES

ACCORDING TO CLIENT'S SPECIFICATIONS

GLASS CABINET 20x20 R1 ACCORDING TO CLIENT'S SPECIFICATIONS.

PROFILE	ANOD. SILVER MAT	ANOD. STAINLESS STEEL	
20x20R1	143.199.512	143.199.560	1

1 PROFILE TO BE MACHINED

20X20 1MM RADIUS

PROFILE TO BE MACHINED

PROFILE TO BE MACHINED 20X20 R1.

	ANOD. SILVER MATT	ANOD. STAINLESS STEEL	
	149.060.516	149.060.564	10

6M. BARS.

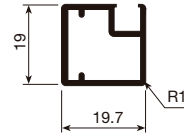

TONGUE-PIECE FOR 4MM GLASS.

TRANSPARENT	753.604.316	50

3M. BARS SUPPLIED IN BOXES OF 50 UNITS. FOR 4MM GLASS.



JOINING FITTINGS.

ZINC-COATED	154.700.033	100

BAGS OF 4 BRACKETS AND 8 SCREWS. FOR 100 DOORS.

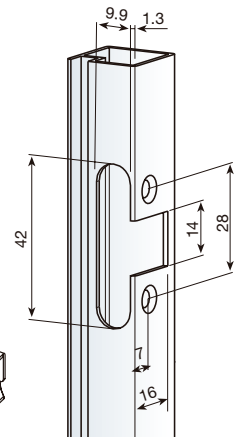
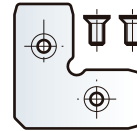

MESUCO 143 RAPID HINGE FOR ALUMINIUM FRAME.

110° OPENING		
FULL OVERLAY	306.000.063	
HALF OVERLAY	306.100.060	50
FULL INSET	306.200.064	

FOR 25 DOORS

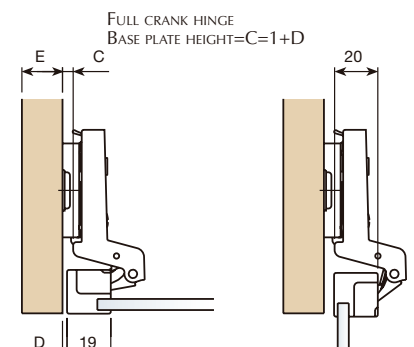
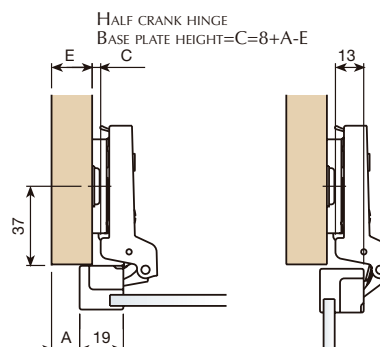
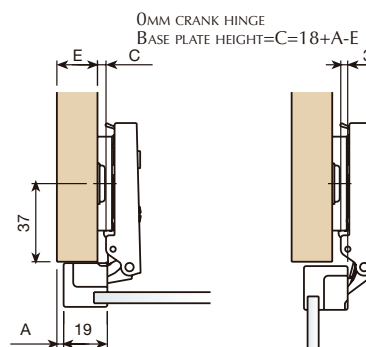
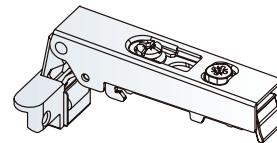

SYSTEM 32 SCREW-FIX MOUNTING PLATE.

CHOCK		
2	083.243.134	200
4	083.243.230	

SUPPLIED IN BAGS OF 500 UNITS. EACH BAG COVERS 25 DOORS.

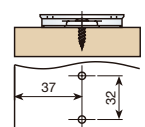
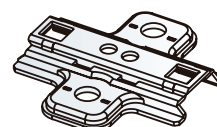

1 MACHINED GLASS CABINETS

20X20 6MM RADIUS

STANDARD KITCHEN

GLASS CABINET 20x20 6MM RADIUS.

MODULE	DIM. GLASS 4MM.	ANOD. SILVER MATT	ANOD. STAINLESS STEEL	
70x30 (698x298)	671x271	143.630.513	143.630.561	1
70x35 (698x348)	671x321	143.635.516	143.635.564	
70x40 (698x398)	671x371	143.640.512	143.640.560	
70x45 (698x448)	671x421	143.645.515	143.645.563	
70x50 (698x498)	671x471	143.650.511	143.650.566	
70x60 (698x598)	671x571	143.660.510	143.660.565	
90x30 (898x298)	871x271	143.830.514	143.830.562	
90x35 (898x348)	871x321	143.835.510	143.835.565	
90x40 (898x398)	871x371	143.840.513	143.840.561	
90x45 (898x448)	871x421	143.845.516	143.845.564	
90x50 (898x498)	871x471	143.850.512	143.850.560	
90x60 (898x598)	871x571	143.860.511	143.860.566	

SUPPLIED MACHINED AND DISMANTLED, WITH THE JOINING FITTINGS AND THE GASKETS FOR 4MM GLASS. IN BOXES OF 1 DOOR.

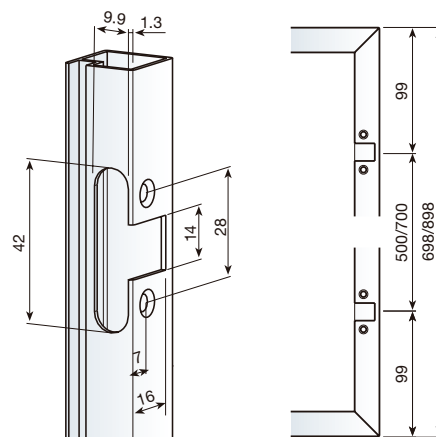
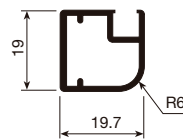

MACHINING AND POSITION OF HINGES

MADE TO MEASURE

GLASS CABINET 20x20 R6 TO MEASURE.

20x20R6	0	143.600.516	143.600.564	1
20x20R6	2	143.602.513	143.602.561	
20x20R6	3	143.603.515	143.603.563	
20x20R6	4	143.604.510	143.604.565	

NOTE

THE POSITION OF THE HINGES IS CALCULATED FROM THE INSIDE OF THE CABINET (MACHINING SIDE). THIS SHOULD BE TAKEN INTO ACCOUNT IN THE CASE OF ASYMMETRIC DOORS.

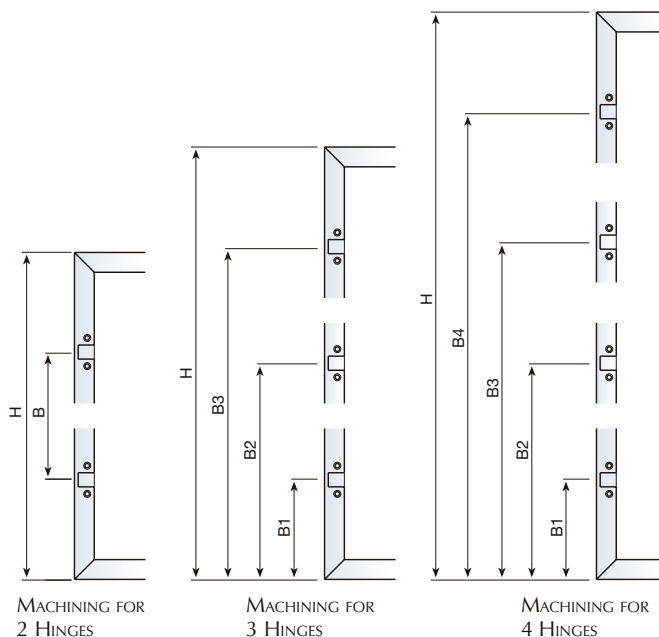

ACCORDING TO CLIENT'S SPECIFICATIONS

GLASS CABINET 20x20 R6 ACCORDING TO CLIENT'S SPECIFICATIONS.

PROFILE	ANOD. SILVER MATT	ANOD. STAINLESS STEEL	
20x20R6	143.699.511	143.699.566	1

1 PROFILE TO BE MACHINED

20X20 6MM RADIUS

PROFILE TO BE MACHINED

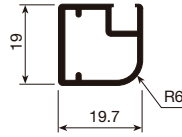

PROFILE TO BE MACHINED 20x20 R6.

ANOD. SILVER MATT	ANOD. STAINLESS STEEL	
149.160.513	149.160.561	10

6M. BARS. SUPPLIED IN BOXES OF 10 UNITS.

TONGUE-PIECE FOR 4MM GLASS.

TRANSPARENT	
753.604.316	50



3M. BARS. SUPPLIED IN BOXES OF 50 UNITS. FOR 4MM GLASS.

JOINING FITTINGS.

ZINC-COATED	
154.700.033	100

BAGS OF 4 BRACKETS AND 8 SCREWS. SUPPLIED IN BOXES OF 100 UNITS FOR 100 DOORS.

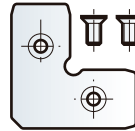

MESUCO 143 RAPID HINGE FOR ALUMINIUM FRAME.

110° OPENING	
FULL OVERLAY	306.000.063
HALF OVERLAY	306.100.060
FULL INSET	306.200.064

FOR 25 DOORS.

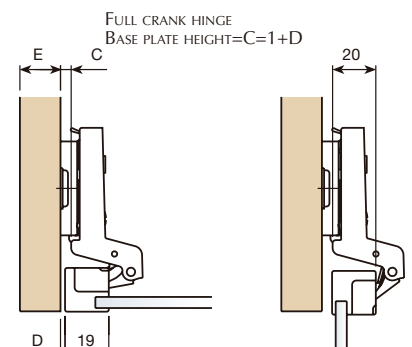
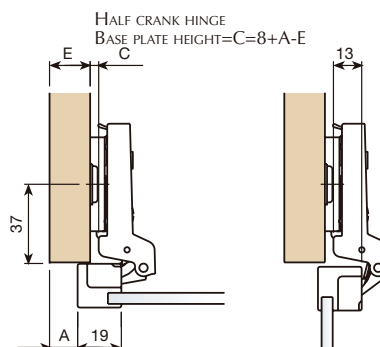
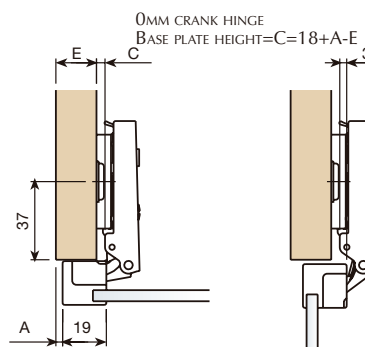
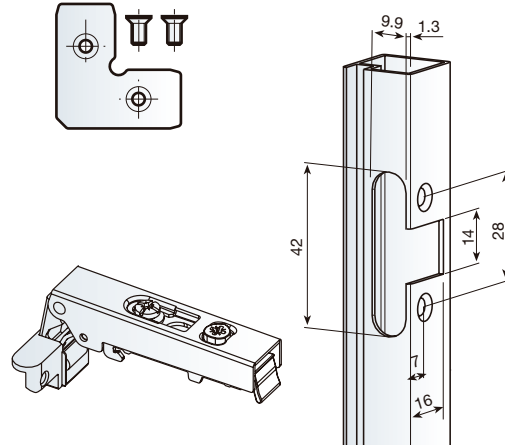

SYSTEM 32 SCREW-FIX MOUNTING PLATE.

CHOCK	
2	083.243.134
4	083.243.230

SUPPLIED IN BAGS OF 50 UNITS. EACH BAG COVERS 25 DOORS.



1 MACHINED GLASS CABINETS

20X20 1MM RADIUS, 7.5MM VISIBLE

STANDARD KITCHEN

GLASS CABINET 20x20x7.5MM. DISPLAYED.

MODULE	DIM. GLASS 4MM.	ANOD. SILVER MATT	ANOD. STAINLESS STEEL
70x30 (698x298)	694x294	144.130.512	144.130.560
70x35 (698x348)	694x344	144.135.515	144.135.563
70x40 (698x398)	694x394	144.140.511	144.140.566
70x45 (698x448)	694x444	144.145.514	144.145.562
70x50 (698x498)	694x494	144.150.510	144.150.565
70x60 (698x598)	694x594	144.160.516	144.160.564
90x30 (898x298)	894x294	144.330.513	144.330.561
90x35 (898x348)	894x344	144.335.516	144.335.564
90x40 (898x398)	894x394	144.340.512	144.340.560
90x45 (898x448)	894x444	144.345.515	144.345.563
90x50 (898x498)	894x494	144.350.511	144.350.566
90x60 (898x598)	894x594	144.360.510	144.360.565

SUPPLIED MACHINED AND DISMANTLED, WITH THE JOINING FITTINGS AND THE GASKETS FOR 4MM GLASS. IN BOXES OF 1 DOOR.

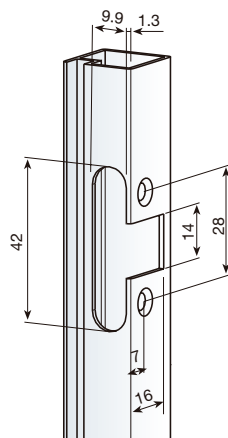
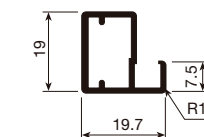

MACHINING AND POSITION OF HINGES

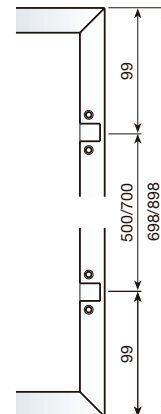

ASSEMBLY OF DOORS WITH CROSS-PIECES

GLASS CABINET WITH ONE 20x20x7.5MM. CROSS-PIECE.

MODULE	DIM. GLASS 4MM.	ANOD. SILVER MATT	ANOD. STAINLESS STEEL
70x30 (698x298)	344x294	144.630.511	144.630.566
70x35 (698x348)	344x344	144.635.514	144.635.562
70x40 (698x398)	344x394	144.640.510	144.640.565
70x45 (698x448)	344x444	144.645.513	144.645.561
70x50 (698x498)	344x494	144.650.516	144.650.564
70x60 (698x598)	344x594	144.660.515	144.660.563
90x30 (898x298)	444x294	144.830.512	144.830.560
90x35 (898x348)	444x344	144.835.515	144.835.563
90x40 (898x398)	444x394	144.840.511	144.840.566
90x45 (898x448)	444x444	144.845.514	144.845.562
90x50 (898x498)	444x494	144.850.510	144.850.565
90x60 (898x598)	444x594	144.860.516	144.860.564

GLASS CABINET WITH TWO 20x20x7.5MM CROSS-PIECES.

MODULE	DIM. GLASS 4MM.	ANOD. SILVER MATT	ANOD. STAINLESS STEEL
228x294	145.130.510	145.130.565	
228x344	145.135.513	145.135.561	
228x394	145.140.516	145.140.564	
228x444	145.145.512	145.145.560	
228x494	145.150.515	145.150.563	
228x594	145.160.514	145.160.562	
294x294	145.330.511	145.330.566	
294x344	145.335.514	145.335.562	
294x394	145.340.510	145.340.565	
294x444	145.345.513	145.345.561	
294x494	145.350.516	145.350.564	
294x594	145.360.515	145.360.563	

SUPPLIED MACHINED AND DISMANTLED, WITH THE JOINING FITTINGS AND THE GASKETS FOR 4MM GLASS. IN BOXES OF 1 DOOR

MADE TO MEASURE

GLASS CABINET 20x20x7.5MM. TO MEASURE.

PROFILE	HINGES	ANOD. SILVER MATT	ANOD. STAINLESS STEEL	SILVER GLOSS
20x20x7.5	0	144.100.515	144.100.563	144.100.106
20x20x7.5	2	144.102.512	144.102.560	144.102.103
20x20x7.5	3	144.103.514	144.103.562	144.103.105
20x20x7.5	4	144.104.516	144.104.564	144.104.100

NOTE

THE POSITION OF THE HINGES IS CALCULATED FROM THE INSIDE OF THE CABINET (MACHINING SIDE). THIS SHOULD BE TAKEN INTO ACCOUNT IN THE CASE OF ASYMMETRIC DOORS.

ACCORDING TO CLIENT'S SPECIFICATIONS

GLASS CABINET 20x20x7.5MM. ACCORDING TO CLIENT'S SPECIFICATIONS.

PROFILE	ANOD. SILVER MATT	ANOD. STAINLESS STEEL	SILVER GLOSS
20x20x7.5	144.199.510	144.199.565	144.199.101

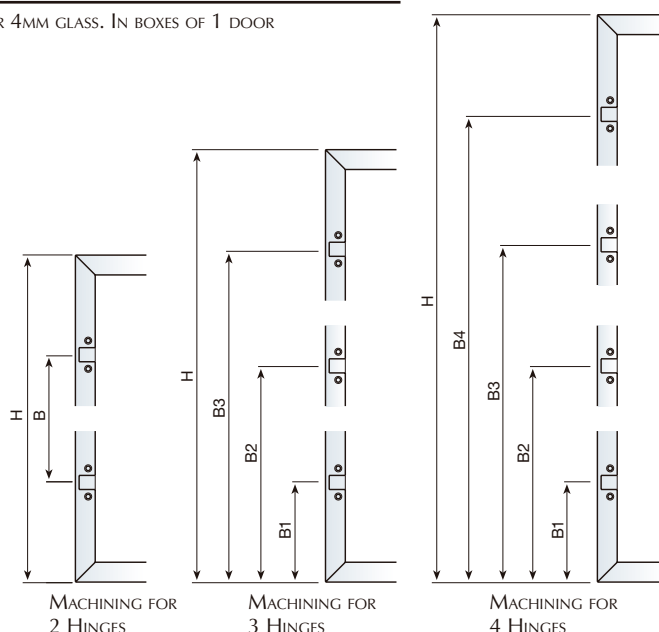

MACHINING FOR 2 HINGES

MACHINING FOR 3 HINGES

MACHINING FOR 4 HINGES

1 PROFILE TO BE MACHINED

20X20 1MM RADIUS, 7,5 VISIBLE

PROFILE TO BE MACHINED

PROFILE TO BE MACHINED 20x20x7.5mm.

ANOD. SILVER MATT	ANOD. STAINLESS STEEL	SILVER GLOSS	
149.260.510	149.260.565	149.260.101	10

6M. BARS. SUPPLIED IN BOXES OF 10 UNITS.

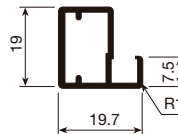

GASKET FOR 4MM. GLASS.

TRANSPARENT		
	753.604.316	50

3M. BARS. SUPPLIED IN BOXES OF 50 UNITS. FOR 4MM GLASS.



JOINING FITTINGS.

ZINC-COATED		
	154.700.033	100

BAGS OF 4 BRACKETS AND 8 SCREWS. SUPPLIED IN BOXES OF 100 UNITS. FOR 100 DOORS.

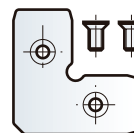

MESUCO 143 RAPID HINGE FOR ALUMINIUM FRAME.

110° OPENING		
FULL OVERLAY	306.000.063	50
HALF OVERLAY	306.100.060	
FULL INSET	306.200.064	

FOR 25 DOORS.

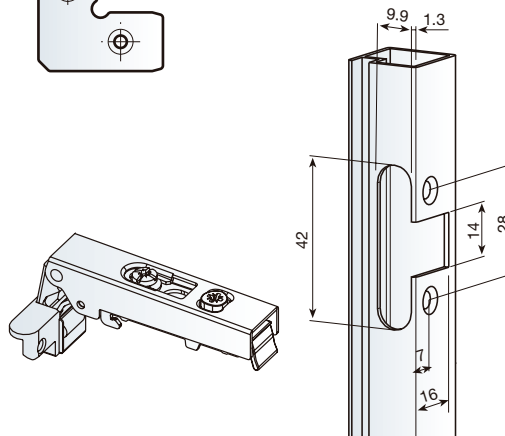

0MM CRANK HINGE
BASE PLATE HEIGHT=C=18+A-E

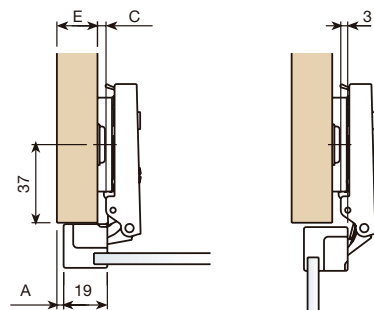

HALF CRANK HINGE
BASE PLATE HEIGHT=C=8+A-E

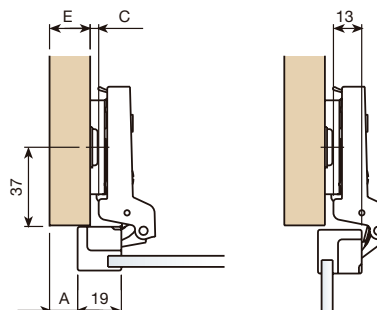

FULL CRANK HINGE
BASE PLATE HEIGHT=C=1+D

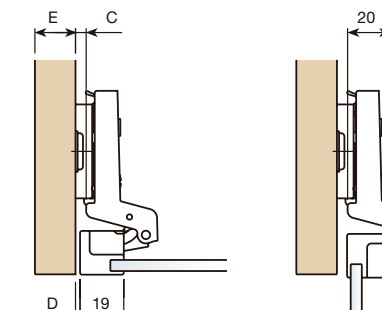

SYSTEM 32 SCREW-FIX MOUNTING PLATE.

CHOCK		
2	083.243.134	200
4	083.243.230	

SUPPLIED IN BAGS OF 50 UNITS. EACH BAG COVERS 2 DOORS.



1 MACHINED GLASS CABINETS

■ 35X20 1MM RADIUS, 7.5MM VISIBLE

■ STANDARD KITCHEN

GLASS CABINET 35x20x7.5MM. DISPLAYED.

MODULE	DIM. GLASS 4MM	ANOD. SILVER MATT	ANOD. STAINLESS STEEL
70x30 (698x298)	694x294	145.630.516	145.630.564
70x35 (698x348)	694x344	145.635.512	145.635.560
70x40 (698x398)	694x394	145.640.515	145.640.563
70x45 (698x448)	694x444	145.645.511	145.645.566
70x50 (698x498)	694x494	145.650.514	145.650.562
70x60 (698x598)	694x594	145.660.513	145.660.561
90x30 (898x298)	894x294	145.830.510	145.830.565
90x35 (898x348)	894x344	145.835.513	145.835.561
90x40 (898x398)	894x394	145.840.516	145.840.564
90x45 (898x448)	894x444	145.845.512	145.845.560
90x50 (898x498)	894x494	145.850.515	145.850.563
90x60 (898x598)	894x594	145.860.514	145.860.562

SUPPLIED MACHINED AND DISMANTLED WITH JOINING FITTINGS AND GASKETS FOR 4 MM GLASS. IN BOXES OF 1 DOOR.

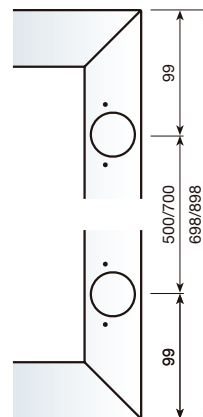
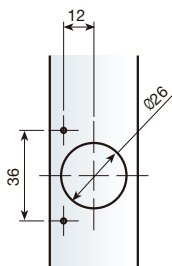
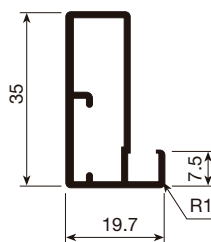

MACHINING AND POSITION OF HINGES

ASSEMBLY OF DOORS WITH CROSS-PIECES

GLASS CABINET WITH ONE 35x20x7.5MM CROSS-PIECE.

MODULE	DIM. GLASS 4MM	ANOD. SILVER MATT	ANOD. STAINLESS STEEL
70x30 (698x298)	344x294	146.130.515	146.130.563
70x35 (698x348)	344x344	146.135.511	146.135.566
70x40 (698x398)	344x394	146.140.514	146.140.562
70x45 (698x448)	344x444	146.145.510	146.145.565
70x50 (698x498)	344x494	146.150.513	146.150.561
70x60 (698x598)	344x594	146.160.512	146.160.560
90x30 (898x298)	444x294	146.330.516	146.330.564
90x35 (898x348)	444x344	146.335.512	146.335.560
90x40 (898x398)	444x394	146.340.515	146.340.563
90x45 (898x448)	444x444	146.345.511	146.345.566
90x50 (898x498)	444x494	146.350.514	146.350.562
90x60 (898x598)	444x594	146.360.513	146.360.561

GLASS CABINET WITH TWO 35x20x7.5MM CROSS-PIECES.

MODULE	DIM. GLASS 4MM	ANOD. SILVER MATT	ANOD. STAINLESS STEEL
228x294	228x294	146.630.514	146.630.562
228x344	228x344	146.635.510	146.635.565
228x394	228x394	146.640.513	146.640.561
228x444	228x444	146.645.516	146.645.564
228x494	228x494	146.650.512	146.650.560
228x594	228x594	146.660.511	146.660.566
294x294	294x294	146.830.515	146.830.563
294x344	294x344	146.835.511	146.835.566
294x394	294x394	146.840.514	146.840.562
294x444	294x444	146.845.510	146.845.565
294x494	294x494	146.850.513	146.850.561
294x594	294x594	146.860.512	146.860.560

SUPPLIED MACHINED AND DISMANTLED WITH JOINING FITTINGS AND GASKETS FOR 4 MM GLASS. IN BOXES OF 1 DOOR.

■ MADE TO MEASURE

GLASS CABINET 35x20x7.5MM. TO MEASURE.

PROFILE	HINGES	ANOD. SILVER MATT	ANOD. STAINLESS STEEL
35x20x7.5	0	145.600.512	145.600.560
35x20x7.5	2	145.602.516	145.602.564
35x20x7.5	3	145.603.511	145.603.566
35x20x7.5	4	145.604.513	145.604.561

NOTE

THE POSITION OF THE HINGES IS CALCULATED FROM THE INSIDE OF THE CABINET (MACHINING SIDE). THIS SHOULD BE TAKEN INTO ACCOUNT IN THE CASE OF ASYMMETRIC DOORS.

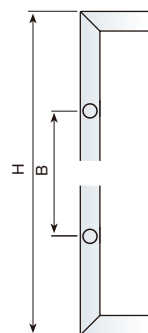
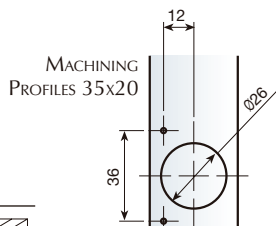

MACHINING FOR 2 HINGES

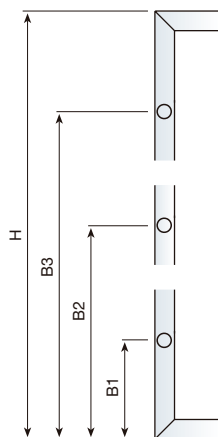

MACHINING FOR 3 HINGES

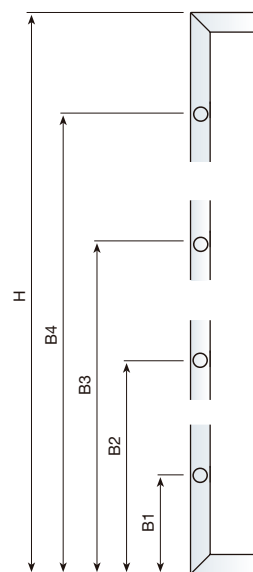

MACHINING FOR 4 HINGES

■ ACCORDING TO CLIENT'S SPECIFICATIONS

GLASS CABINET 35x20x7.5MM. ACCORDING TO CLIENT'S SPECIFICATIONS.

PROFILE	ANOD. SILVER MATT	ANOD. STAINLESS STEEL
30x20x7.5	145.699.514	145.699.562

1 PROFILE TO BE MACHINED

■ 35X20 1MM RADIUS, 7.5MM VISIBLE

■ PROFILE TO BE MACHINED

PROFILE TO BE MACHINED 30x20x7.5mm.

	ANOD. SILVER MATT	ANOD. STAINLESS STEEL	
	149.360.514	149.360.562	 10

6M. BARS. SUPPLIED IN BOXES OF 10 UNITS.

GASKET FOR 4MM GLASS.

TRANSPARENT	753.604.316	 50

3M. BARS. SUPPLIED IN BOXES OF 50 UNITS. FOR 4MM GLASS.

JOINING FITTINGS.

ZINC-COATED	154.700.033	 100

BAGS OF 4 BRACKETS AND 8 SCREWS. SUPPLIED IN BOXES OF 100 UNITS. FOR 100 DOORS.

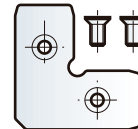
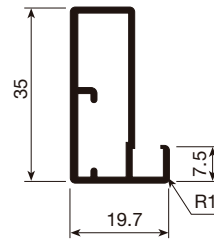

1 MACHINED GLASS CABINETS

45X20 1MM RADIUS, 7.5MM VISIBLE

STANDARD KITCHEN

GLASS CABINET 45X20X7.5MM. DISPLAYED.

MODULE	DIM. GLASS 4MM.	ANOD. SILVER MATT	ANOD. STAINLESS STEEL
70x30 (698x298)	694x294	147.630.512	147.630.560
70x35 (698x348)	694x344	147.635.515	147.635.563
70x40 (698x398)	694x394	147.640.511	147.640.566
70x45 (698x448)	694x444	147.645.514	147.645.562
70x50 (698x498)	694x494	147.650.510	147.650.565
70x60 (698x598)	694x594	147.660.516	147.660.564
90x30 (898x298)	894x294	147.830.513	147.830.561
90x35 (898x348)	894x344	147.835.516	147.835.564
90x40 (898x398)	894x394	147.840.512	147.840.560
90x45 (898x448)	894x444	147.845.515	147.845.563
90x50 (898x498)	894x494	147.850.511	147.850.566
90x60 (898x598)	894x594	147.860.510	147.860.565

SUPPLIED MACHINED AND DISMANTLED WITH JOINING FITTINGS AND GASKETS FOR 4 MM GLASS. IN BOXES OF 1 DOOR.

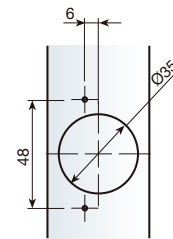
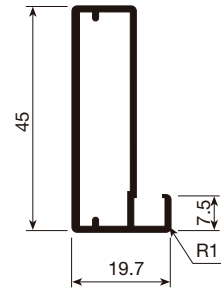

MACHINING AND POSITION OF HINGES

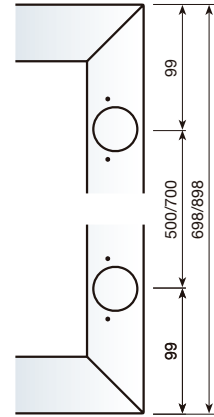

ASSEMBLY OF DOORS WITH CROSS-PIECES

GLASS CABINET WITH ONE CROSS-PIECE 45X20X7.5MM.

MODULE	DIM. GLASS 4MM.	ANOD. SILVER MATT	ANOD. STAINLESS STEEL
70x30 (698x298)	344x294	148.130.511	148.130.566
70x35 (698x348)	344x344	148.135.514	148.135.562
70x40 (698x398)	344x394	148.140.510	148.140.565
70x45 (698x448)	344x444	148.145.513	148.145.561
70x50 (698x498)	344x494	148.150.516	148.150.564
70x60 (698x598)	344x594	148.160.515	148.160.563
90x30 (898x298)	444x294	148.330.512	148.330.560
90x35 (898x348)	444x344	148.335.515	148.335.563
90x40 (898x398)	444x394	148.340.511	148.340.566
90x45 (898x448)	444x444	148.345.514	148.345.562
90x50 (898x498)	444x494	148.350.510	148.350.565
90x60 (898x598)	444x594	148.360.516	148.360.564

SUPPLIED MACHINED AND DISMANTLED WITH JOINING FITTINGS AND GASKETS FOR 4 MM GLASS. IN BOXES OF 1 DOOR.

GLASS CABINET WITH TWO CROSS-PIECES 45X20X7.5MM.

MODULE	DIM. GLASS 4MM.	ANOD. SILVER MATT	ANOD. STAINLESS STEEL
228x294	228x294	148.630.510	148.630.565
228x344	228x344	148.635.513	148.635.561
228x394	228x394	148.640.516	148.640.564
228x444	228x444	148.645.512	148.645.560
228x494	228x494	148.650.515	148.650.563
228x594	228x594	148.660.514	148.660.562
294x294	294x294	148.830.511	148.830.566
294x344	294x344	148.835.514	148.835.562
294x394	294x394	148.840.510	148.840.565
294x444	294x444	148.845.513	148.845.561
294x494	294x494	148.850.516	148.850.564
294x594	294x594	148.860.515	148.860.563

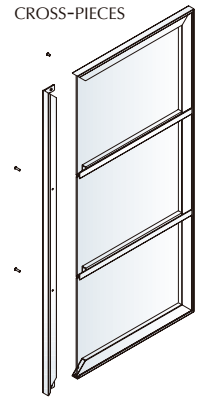

MADE TO MEASURE

GLASS CABINET 45X20X7.5 MM. TO MEASURE.

PROFILE	HINGES	ANOD. SILVER MATT	ANOD. STAINLESS STEEL
45x20x7.5	0	147.600.515	147.600.563
45x20x7.5	2	147.602.512	147.602.560
45x20x7.5	3	147.603.514	147.603.562
45x20x7.5	4	147.604.516	147.604.564

NOTE

THE POSITION OF THE HINGES IS CALCULATED FROM THE INSIDE OF THE CABINET (MACHINING SIDE). THIS SHOULD BE TAKEN INTO ACCOUNT IN THE CASE OF ASYMMETRIC DOORS.

ACCORDING TO CLIENT'S SPECIFICATIONS

GLASS CABINET 45X20X7.5 MM. ACCORDING TO CLIENT'S SPECIFICATIONS.

PROFILE	ANOD. SILVER MATT	ANOD. STAINLESS STEEL	SILVER GLOSS
45x20x7.5	147.699.510	147.699.565	147.699.101

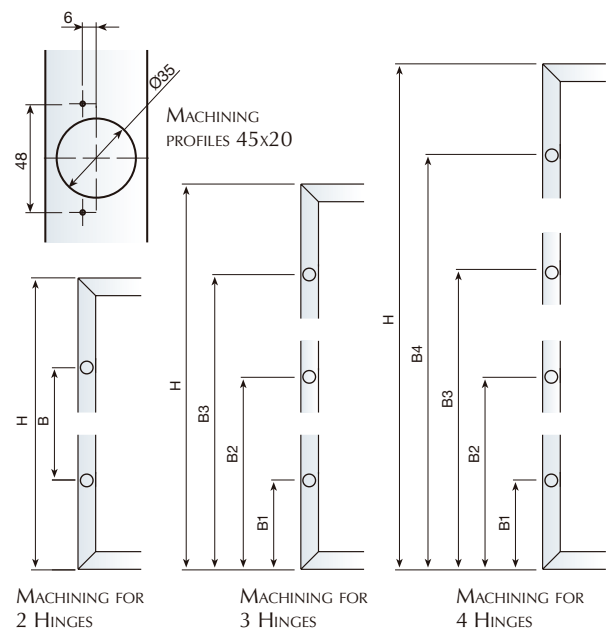

MACHINING FOR 2 HINGES

MACHINING FOR 3 HINGES

MACHINING FOR 4 HINGES

1 PROFILE TO BE MACHINED

■ 45X20 1MM RADIUS, 7.5MM VISIBLE

■ PROFILE TO BE MACHINED

PROFILE TO BE MACHINED 45x20x7.5mm.

ANOD. SILVER MATT	ANOD. STAINLESS STEEL	SILVER GLOSS	BLACK	
149.560.515	149.560.563	149.560.106	149.560.541	10

6M. BARS. SUPPLIED IN BOXES OF 10 UNITS.

GASKET FOR 4MM GLASS.

TRANSPARENT	753.604.316	
		50

3M. BARS. SUPPLIED IN BOXES OF 50 UNITS. FOR 4MM GLASS.

JOINING FITTINGS.

ZINC-COATED	154.800.030	
		100

BAGS OF 4 BRACKETS AND 8 SCREWS. SUPPLIED IN BOXES OF 100 UNITS. FOR 100 DOORS

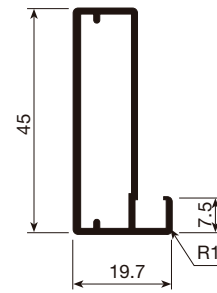

1 MACHINED GLASS CABINETS

45X20 1.2 VISIBLE

STANDARD KITCHEN

GLASS CABINET 45x20x1.2 FOR ADHERED GLASS.

MODULE	DIM. GLASS 4MM.	ANOD. SILVER MATT	ANOD. STAINLESS STEEL	
70x30 (698x298)	695x295	147.130.513	147.130.561	1
70x35 (698x348)	695x345	147.135.516	147.135.564	
70x40 (698x398)	695x395	147.140.512	147.140.560	
70x45 (698x448)	695x445	147.145.515	147.145.563	
70x50 (698x498)	695x495	147.150.511	147.150.566	
70x60 (698x598)	695x595	147.160.510	147.160.565	
90x30 (898x298)	895x295	147.330.514	147.330.562	
90x35 (898x348)	895x345	147.335.510	147.335.565	
90x40 (898x398)	895x395	147.340.513	147.340.561	
90x45 (898x448)	895x445	147.345.516	147.345.564	
90x50 (898x498)	895x495	147.350.512	147.350.560	
90x60 (898x598)	895x595	147.360.511	147.360.566	

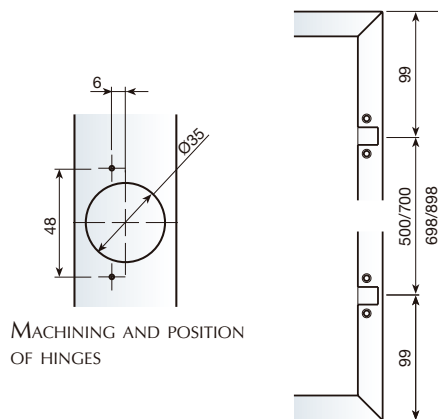
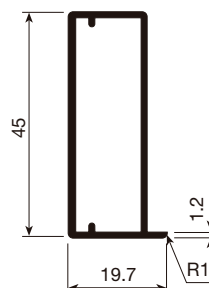

SUPPLIED MACHINED AND DISMANTLED WITH JOINING FITTINGS AND GASKETS FOR 4 MM GLASS. IN BOXES OF 1 DOOR.

MADE TO MEASURE

GLASS CABINET 45x20x1.2 TO MEASURE.

PROFILE	HINGES	ANOD. SILVER MATT	ANOD. STAINLESS STEEL	
45x20x1.2	0	147.100.516	147.100.564	1
45x20x1.2	2	147.102.513	147.102.561	
45x20x1.2	3	147.103.515	147.103.563	
45x20x1.2	4	147.104.510	147.104.565	

NOTE

THE POSITION OF THE HINGES IS CALCULATED FROM THE INSIDE OF THE CABINET (MACHINING SIDE). THIS SHOULD BE TAKEN INTO ACCOUNT IN THE CASE OF ASYMMETRIC DOORS.

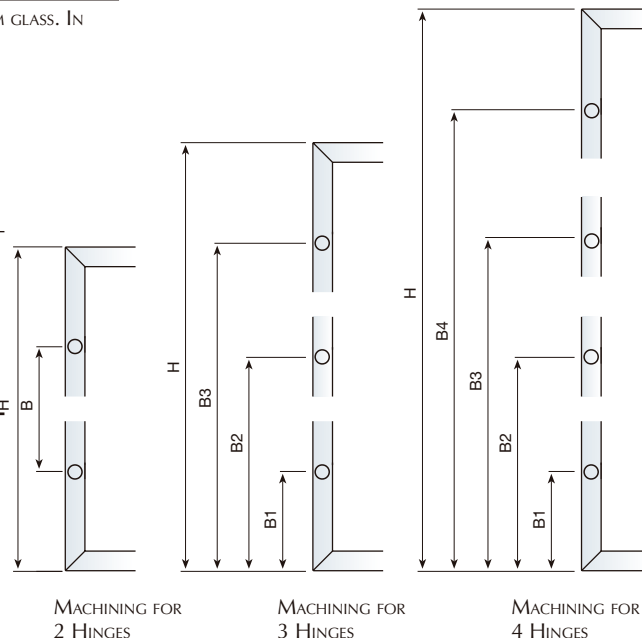
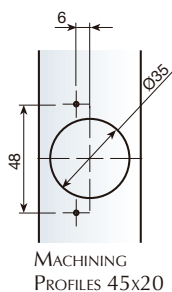

ACCORDING TO CLIENT'S SPECIFICATIONS

GLASS CABINET 45x20x1.2 ACCORDING TO CLIENT'S SPECIFICATIONS.

PROFILE	ANOD. SILVER MATT	ANOD. STAINLESS STEEL	
45x20x1.2	147.199.511	147.199.566	1

1 PROFILE TO BE MACHINED

45X20 1.2 VISIBLE

PROFILE TO BE MACHINED

PROFILE TO BE MACHINED 45x20x1.2MM.

	ANOD. SILVER	ANOD. STAINLESS	
	149.460.511	149.460.566	10

6M. BARS. SUPPLIED IN BOXES OF 10 UNITS.

JOINING FITTINGS.

		
ZINC-COATED	154.800.030	100

BAGS OF 4 BRACKETS AND 8 SCREWS. SUPPLIED IN BOXES OF 100 UNITS. FOR 100 DOORS.

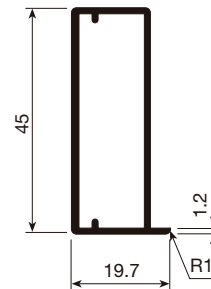

1 MACHINED GLASS CABINETS

45X20X20 VISIBLE

MADE TO MEASURE

GLASS CABINET 45x20x20 TO MEASURE.

PROFILE	HINGES	ANOD. SILVER MATT	
45x20x20	0	147.500.511	1
45x20x20	2	147.502.515	
45x20x20	3	147.503.510	
45x20x20	4	147.504.512	

NOTE

THE POSITION OF THE HINGES IS CALCULATED FROM THE INSIDE OF THE CABINET (MACHINING SIDE). THIS SHOULD BE TAKEN INTO ACCOUNT IN THE CASE OF ASYMMETRIC DOORS.

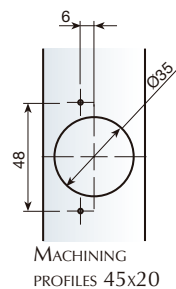
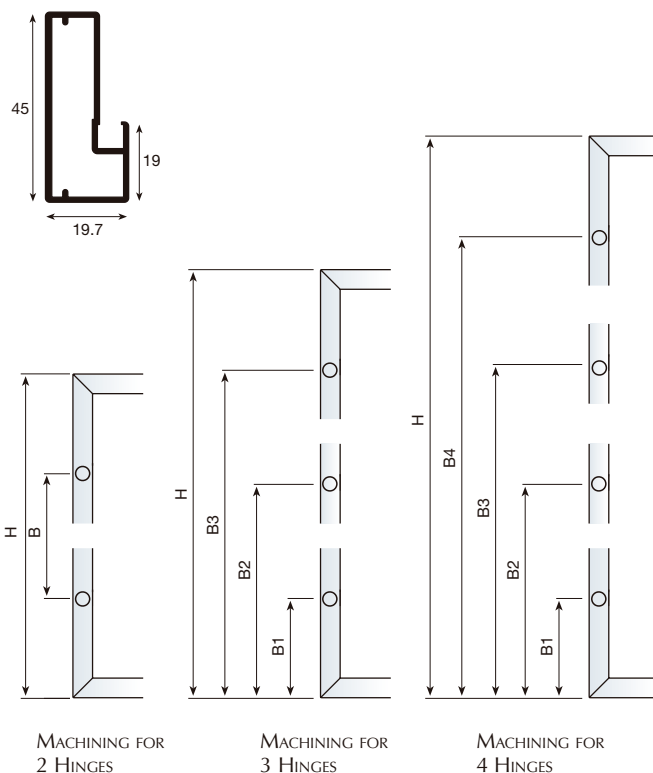

ACCORDING TO CLIENT'S SPECIFICATIONS

GLASS CABINET 45x20x20 ACCORDING TO CLIENT'S SPECIFICATIONS.

PROFILE	ANOD. SILVER MATT	
45x20x20	147.599.513	1

1 PROFILE TO BE MACHINED

45X20X20 VISIBLE

PROFILE TO BE MACHINED

PROFILE TO BE MACHINED 45x20x20MM.

	ANOD. SILVER MATT	
	151.760.512	10

6M. BARS. SUPPLIED IN BOXES OF 10 UNITS.

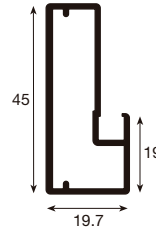

GASKET FOR 4MM GLASS.

	TRANSPARENT	753.604.316	
			50

3M. BARS. SUPPLIED IN BOXES OF 50 UNITS. FOR 4MM GLASS.



JOINING FITTINGS.

	ZINC-COATED	154.800.030	
			100

BAGS OF 4 BRACKETS AND 8 SCREWS. SUPPLIED IN BOXES OF 100 UNITS. FOR 100 DOORS.

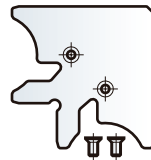

1 MACHINED GLASS CABINETS

50X20X7.5 VISIBLE

MADE TO MEASURE

GLASS CABINET 50x20x7.5 MADE TO MEASURE.

PROFILE	HINGES	ANOD. SILVER MATT	
50x20x7.5	0	147.700.512	1
50x20x7.5	2	147.702.516	
50x20x7.5	3	147.703.511	
50x20x7.5	4	147.704.513	

NOTE

THE POSITION OF THE HINGES IS CALCULATED FROM THE INSIDE OF THE CABINET (MACHINING SIDE). THIS SHOULD BE TAKEN INTO ACCOUNT IN THE CASE OF ASYMMETRIC DOORS.

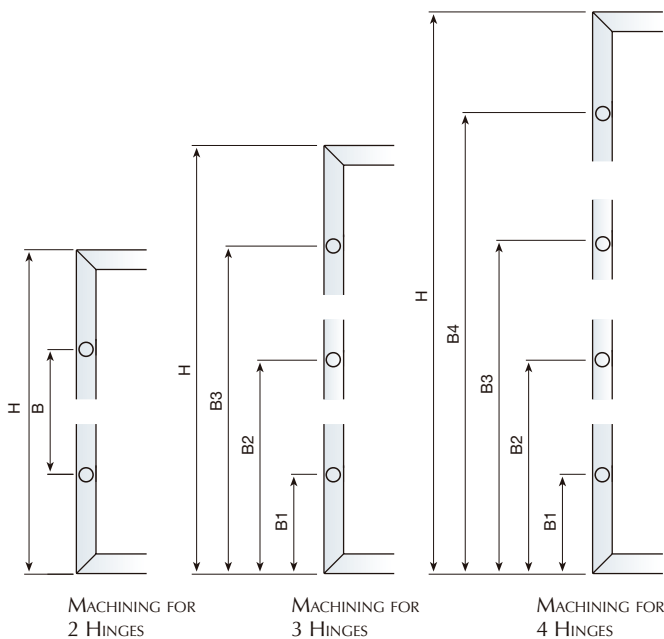
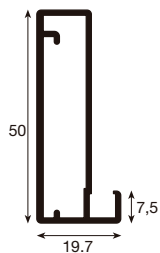
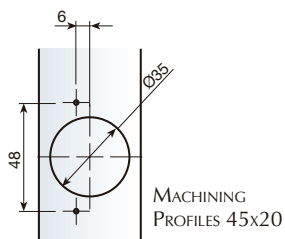

ACCORDING TO CLIENT'S SPECIFICATIONS

GLASS CABINET 45x20x20 ACCORDING TO CLIENT'S SPECIFICATIONS.

PROFILE	ANOD. SILVER MATT	
50x20x7.5	147.799.514	1

1 PROFILE TO BE MACHINED

50X20X7.5 VISIBLE

PROFILE TO BE MACHINED

PROFILE TO BE MACHINED 50x20x7.5MM.

	ANOD. SILVER MATT	
	151.860.516	10

6M. BARS. SUPPLIED IN BOXES OF 10 UNITS.

GASKET FOR 4MM GLASS.

	TRANSPARENT	
	753.604.316	50

3M. BARS. SUPPLIED IN BOXES OF 50 UNITS. FOR 4MM GLASS.

JOINING FITTINGS.

	ZINC-COATED	
	154.800.030	100

BAGS OF 4 BRACKETS AND 8 SCREWS. SUPPLIED IN BOXES OF 100 UNITS. FOR 100 DOORS.

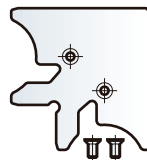
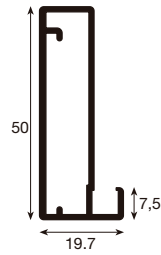

2 UNMACHINED: "SCREEN KIT"

ALUMINIUM PROFILE FOR 4 MM. GLASS.

		
MAT ANODIZED	150.630.513	20

3M. BARS. FOR 4MM GLASS.



ALUMINIUM PROFILE.

		
ANODIZED SILVER MATT	150.930.500	20

3M. BARS. FOR 4MM GLASS.

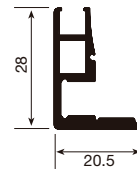

PLASTIC COVER PROFILE.

		
GREY	150.730.311	20

3M. BARS



PLASTIC TONGUE-PIECE.

		
TRANSLUCENT	753.604.316	50

3M. BARS. FOR 4MM GLASS.



CORNER BRACKET.

ZINC PLATED	523.200.031	100
-------------	-------------	-----

FOR 25 DOORS.

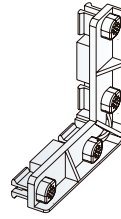

MESUCO 143 HINGE PROGRAM FOR CLAMP MOUNTING.

OPENING 110		50
FULL OVERLAY	060.093.073	
HALF OVERLAY	061.193.075	50
FULL INSET	062.193.073	

FOR 25 DOORS.

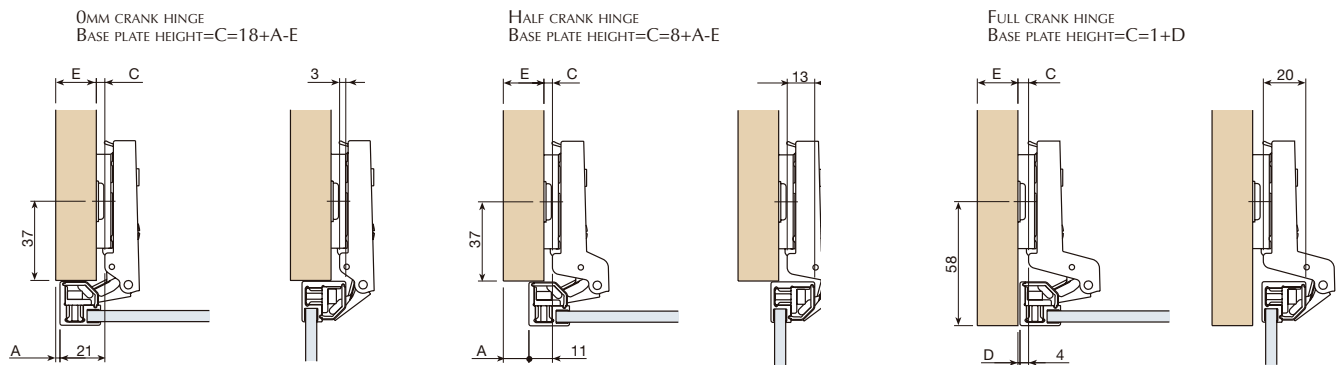
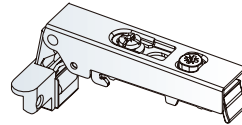

MOUNTING PLATES (SCREW-FIX).

HEIGHT		200
2	083.243.134	
4	083.243.230	

BAGS CONTAINING 50 PCES.



OTHER ADAPTORS.

110° OPENING		50
INDEPENDENT SYSTEM 32 ADAPTOR	526.200.032	
WITH BASE FOR DELTA LIFTING DEVICE	526.300.036	50
WITH BASE FOR PNEUMATIC PIVOT ARM	526.400.033	

FOR 25 DOORS.

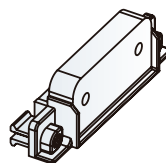

SYSTEM 32 HOLES

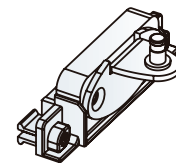

DELTA STAY ADAPTOR
GAS STAY ADAPTOR

■ TECHNICAL DATA

Assembly

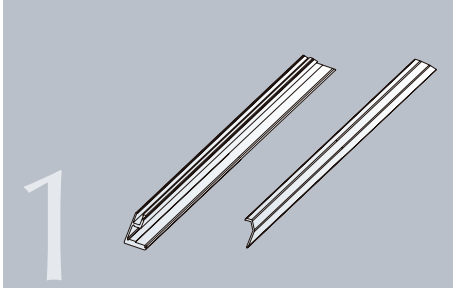

CUT ALUMINIUM AND PLASTIC SIDES TO REQUIRED SIZE.

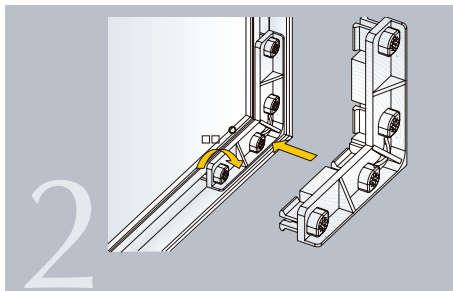

FIT PLASTIC TONGUE-PIECE AND GLASS. FIX USING CORNER BRACKETS. TURN EXPANSION CAM 90°. THE DOOR IS READY.

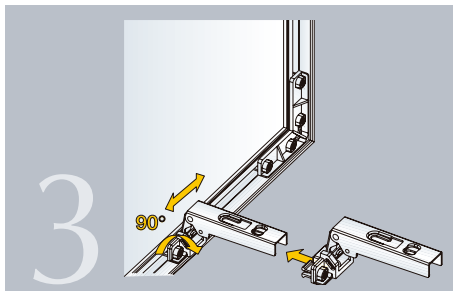

MOUNT HINGES, PRESSING CUPS LIGHTLY. AFTER MOUNTING, THE HINGE CAN BE EASILY DISPLACED ALONG THE PROFILE. TURN EXPANSION CAM 90°

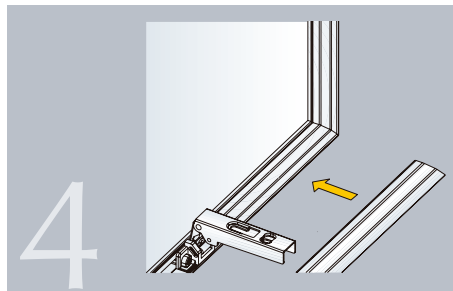

FINISH USING THE PLASTIC COVER PROFILE.